



# ASSEMBLY INSTRUCTION

## etherCON | NE8MX6\* - CAT6A Cable Connector

**Tools:**

- HX-CAT6A or pliers wrench
- Wire cutter

**Wire size: Solid:** AWG 24/1 - AWG 22/1  
**Stranded:** AWG 24/7 - AWG 22/7  
**Insulation Diameter:** > 1.10 - 1.60 mm

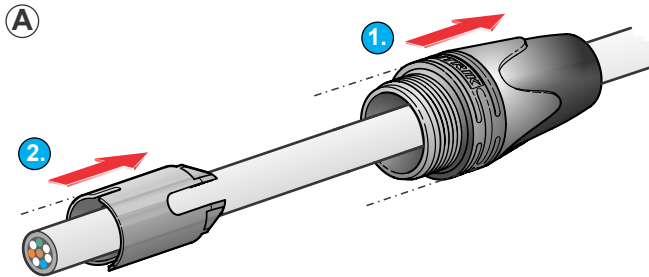

**(A)** Slide the boot (1.) and the chuck (2.) onto the cable.

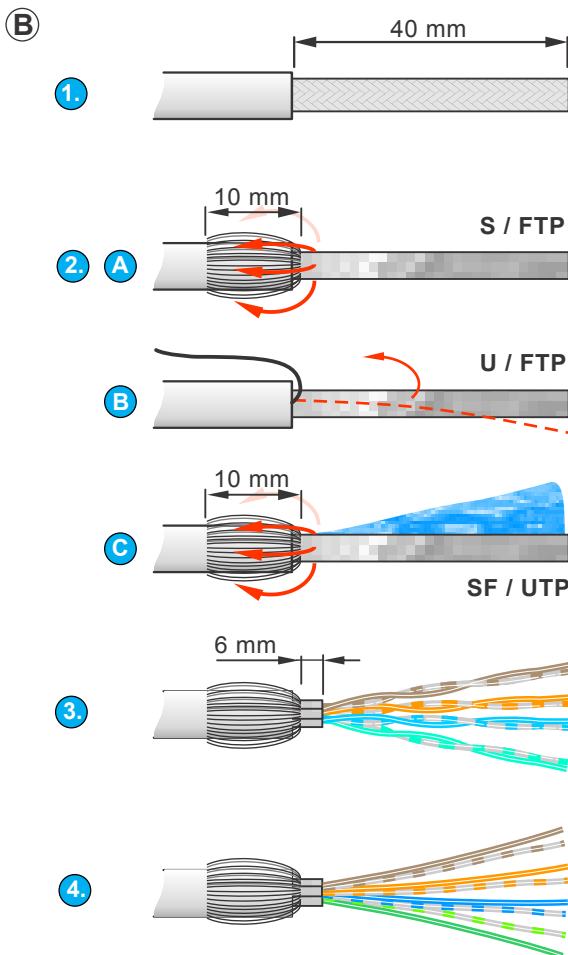

**(B)** 1. Prepare the cable as shown and strip the jacket at a length of 40 mm.

2. **A. S / FTP**

Cut off braided shield to approx 10 mm and fold the shield backwards.

**B. U / FTP**

Remove the foil of the paired wires and bend back the drain wire for easier handling during assembly. Drain wire to be used for grounding.

**C. SF / UTP**

Cut off braided shield to approx 10 mm and fold the shield backwards. Cut and remove the foil screen.

3. Remove the pair screening (if existing) to max. 6 mm.

4. Presort and untwist the pairs as shown.

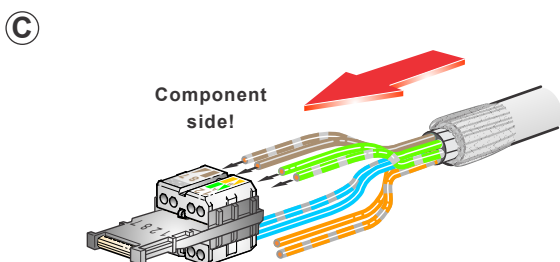

**(C)** Insert the wires into the designated position of the wire management as per below wiring scheme, either T568A or T568B

Component side!	
1 2 8 7	
3 6 4 5	

Connection		
Color code		RJ 45 PIN No.
T568A	T568B	
W - G	W - O	1
G	O	2
W - O	W - G	3
BL	BL	4
W - BL	W - BL	5
O	G	6
W - BR	W - BR	7
BR	BR	8

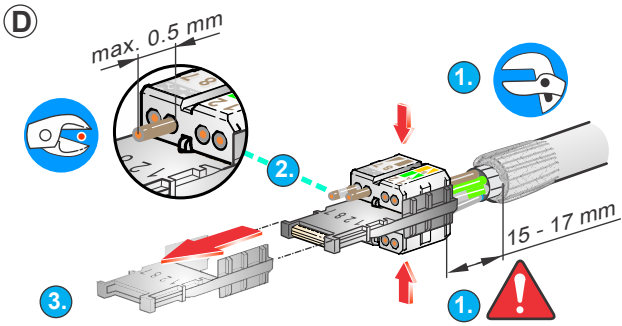

- D** 1. Use HX-CAT6A or pliers wrench to press the wire management together.

**Attention:**  
Distance between the cable jacket and the wire management shall not exceed 15 - 17 mm.

2. Cut all wires with a wire cutter.  
Allow wires to protrude max. 0.5 mm.
3. Remove the assembly guidance.

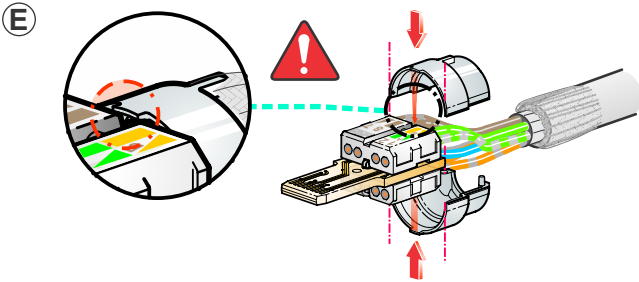

- E** Position the ground-shells over the wires as shown.

**Attention:**  
Align the coding rip of the ground shell and the groove of the wire management.

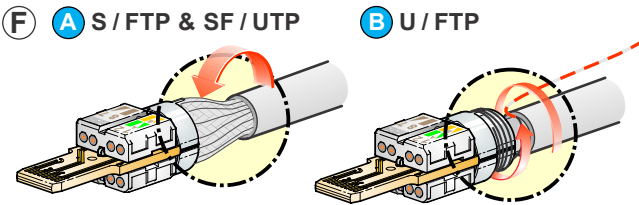

- F** **A.** Put the cable-shield over the ground shell and distribute the shield wires circumferentially.

**B.** Put the drain wire over the ground shell and wrap the drain wire circumferentially.

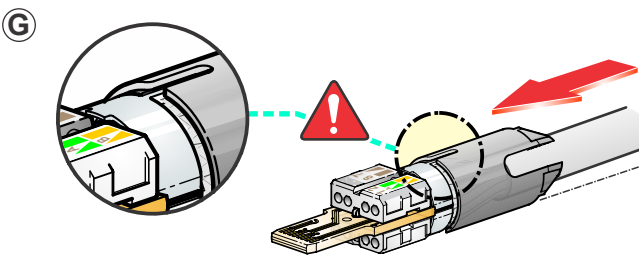

- G** Slide the chuck over the cable-shield / drain wire and the ground shell towards the end-position.

**Attention:**  
Align the slots of the chuck to the ribs of the ground shell.

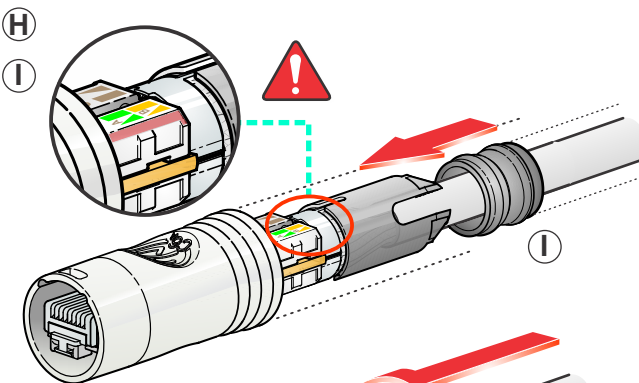

- H** Slide the pre assembled cable (step G) into the housing.

**Attention:**  
Align the wire management keying with the connector housing. Neutrik logo to face upwards.

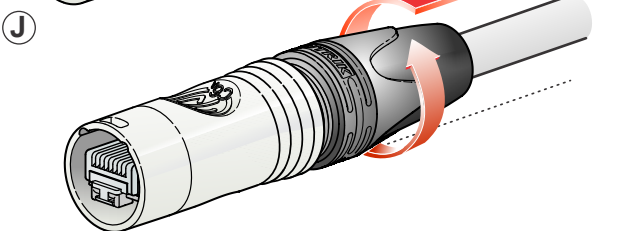

- I** Slide the gasket onto the chuck.

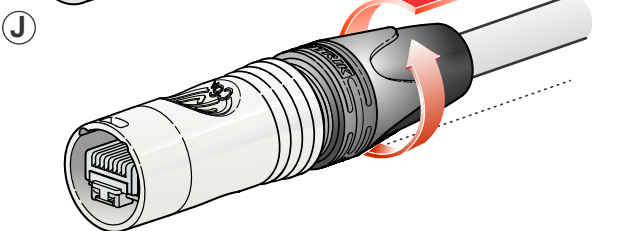

- J** Finish the installation by turning the bushing onto the connector.