

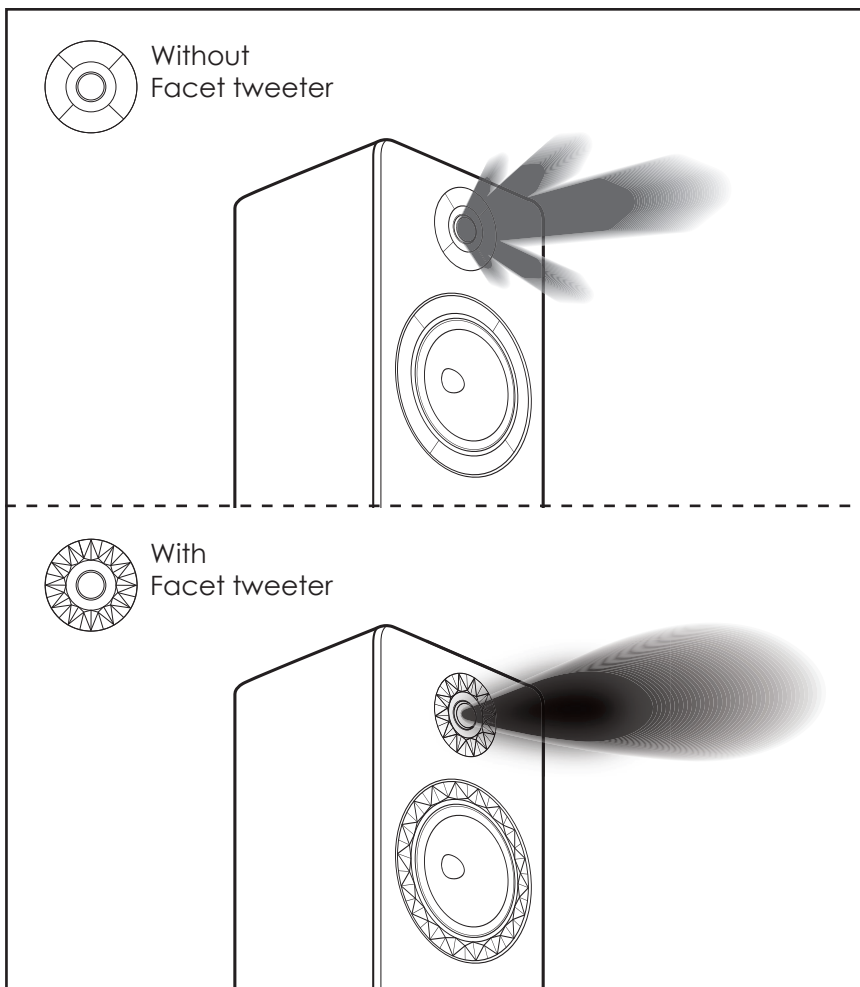

Prestige Facet

Acoustics & Technical Features



Facet surround rings

Facet like Diamond facet, there are complex shape surrounding our drivers. If this shape is aesthetic it also has a very important feature: to minimize the front baffle effect and to polarize in a perfect symmetric way, the high frequencies to get airy, and clear tremble without any auditory fatigue. This facet ring is made in inert material, by alternating flat surfaces, dimples and angles

Taylor made drive units

The dome tweeter is made in coated silk. The large magnet provides high sensitivity. The aluminium face plate damped with the facet ring offers a mechanical reference against the micro-vibrations that may occur at high level.

The midwoofer and woofer have excellent mechanical matching. They are an thoughtful assembly of a slightly coated paper cone, a low loss rubber surround, a concave dust cap that perfectly matches the cone profile for bass. For mid-woofer and midrange, an aluminium phase plug ensures better natural crossover with high frequencies.

Basic damping

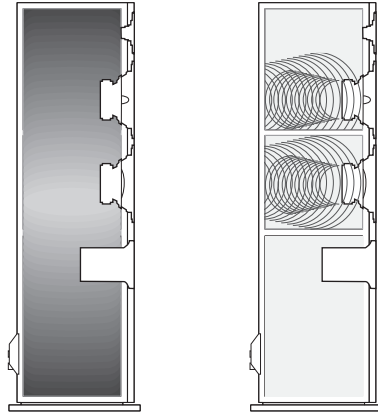

Prestige Facet damping

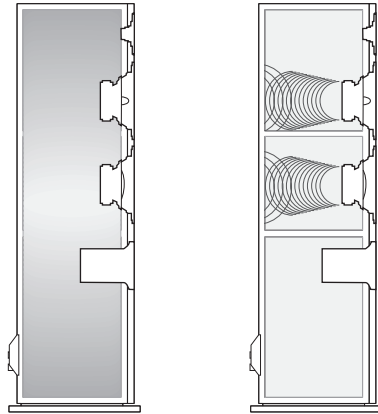

Optimized damping

To minimize cabinet vibrations, the front consists in two wood panels with different thicknesses. The floorstanding cabinet is strongly braced.

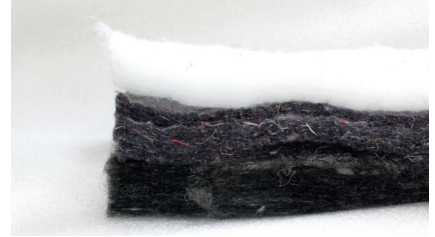

Damping has not been neglected even if it is a hidden part of the loudspeaker. The whole damping consists on different damping fabrics depending on its function and its position. Hence we strongly reduce internal standing waves mainly the direct vertical one, and the ones behind the bass drive units whilst avoiding any muffled sound.

Terminals

Elipson designed bi-wire binding post for conducting the perfect input signal from start.



High slope crossovers

At least, crossovers have been carefully designed according to latest numerical modelling process and finally tuned by our golden ears team during many listening sessions. Then no compromise was made, our crossover contains high quality components such as metallized polyester capacitors (MKT), metal oxide film resistors at strategic locations, inductors with low internal resistance (DCR) offering efficient power transfer.

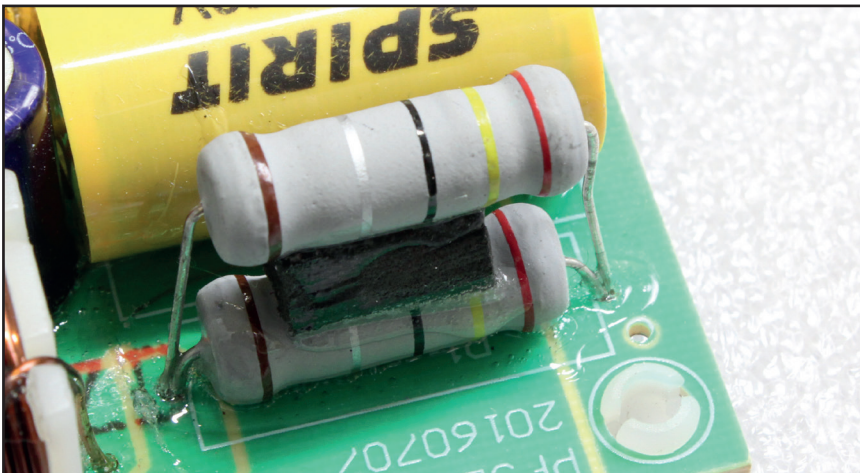



Prestige Facet 6B

Loudspeaker : Bookshelf 2-way bass-reflex
Power : 70W RMS
Mid-bass driver : 140 mm
Tweeter : 25 mm
Frequency response : 57Hz-25kHz
Sensitivity : 90dB/1W/1m
Impedance : 6 Ohms
Terminals : silver plated for bi-wiring
or bi-amp
Dimensions : L176 x H298 x P225 mm
Weight : 5,6 kg
Finishes : black, white, black/walnut



Prestige Facet 8B

Loudspeaker : Bookshelf 2-way bass-reflex
Power : 85W RMS
Mid-bass driver : 170 mm
Tweeter : 25 mm
Frequency response : 47Hz-25kHz
Sensitivity : 91dB/1W/1m
Impedance : 6 Ohms
Terminals : silver plated for bi-wiring
or bi-amp
Dimensions : L230 x H361 x P347 mm
Weight (with stand) : 8 kg (9,3 kg)
Finishes : black, white, black/walnut



Prestige Facet 14F

Loudspeaker : Floorstanding 2½-way bass-reflex
Power : 150W RMS
Woofer : 170 mm
Mid-bass driver : 170 mm
Tweeter : 25 mm
Frequency response : 38Hz-25kHz
Sensitivity : 92dB/1W/1m
Impedance : 6 Ohms
Terminals : silver plated for bi-wiring
or bi-amp
Dimensions : L238 x H1011 x P351 mm
Weight (with stand) : 17,5 kg (20,5 kg)
Finishes : black, white, black/walnut



Prestige Facet 24F coming soon

Loudspeaker : Floorstanding 3-way bass-reflex
Power : 250W RMS
Woofer : 2 x 210 mm
Mid-bass driver : 170 mm
Tweeter : 25 mm
Frequency response : 28Hz-25kHz
Sensitivity : 93dB/1W/1m
Impedance : 6 Ohms
Terminals : silver plated for bi-wiring
or bi-amp
Dimensions : L274 x H1120 x P384 mm
Weight (with stand) : 27 kg (28,5 kg)
Finishes : black, white, black/walnut