

## GH8

### 8" high performance full-range loudspeaker

Thank you for choosing KGEAR!

To ensure proper operation, please carefully read this owner's manual and safety instruction before using the product. After reading this manual, be sure to keep it for future reference.

If you have any questions about your new device please contact K-array customer service at [support@k-array.com](mailto:support@k-array.com) or contact the local distributor in your country.

The GH8 is a medium-sized, compact, and functional addition to the GH family. It features an 8" full-range dual-cone driver, delivering clear and powerful sound across a wide frequency range, even in challenging acoustic environments. The cardioid dispersion pattern reduces rear sound emission, minimizing energy loss and residual noise, achieving up to 129dB SPL per unit.

Housed in a durable stainless steel enclosure with an IP64 rating, the GH8 is designed to withstand outdoor applications. It integrates Pure Array Technology (PAT) and Slim Array Technology (SAT) for optimized sound coverage and performance. The speaker is equipped with 2x SpeakON connectors for signal input and linking, as well as a 4-pin Euroblock connector for secure connections in fixed installation applications.

The GH8 is ideal for live performances, events, or fixed installations, offering flexibility in setup and exceptional sound quality.



## Unpacking

Each KGEAR device is inspected before leaving the factory. Upon arrival, carefully inspect the shipping carton, then examine and test your new device. If you find any damage, immediately notify the shipping company. Check that the following parts are supplied with the product:

- A. 1 x GH8 - 8" full-range loudspeaker
- B. 1x Euroblock speaker connector (MC 1.5/4-ST-31: 1N)

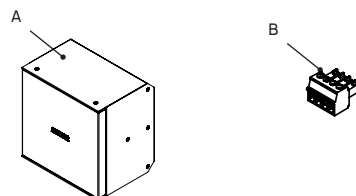

## GH8 rear panel

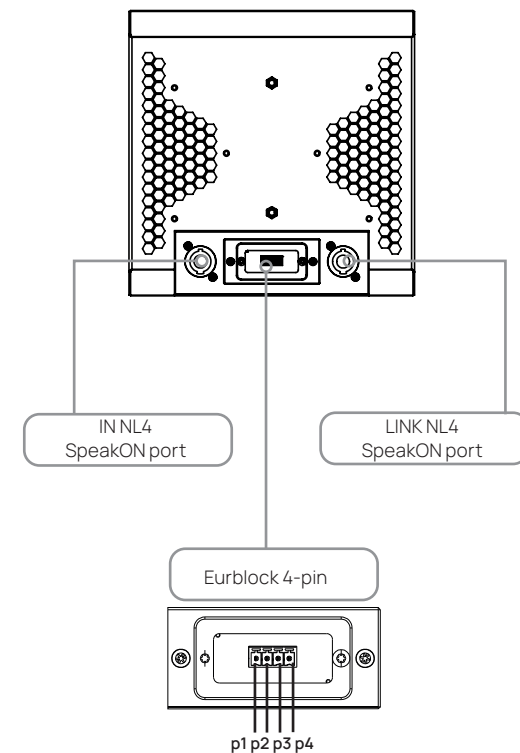

## Wiring with NL4 speakON connectors

The GH8 speaker is equipped with 2x speakON NL4 connectors to facilitate easy connection of multiple speakers. Follow this guide for proper pass-through wiring:

### SpeakON connectors terminals wiring

A) Terminals 1+ and 1-:

These terminals are connected internally to the GH8's dual-cone driver.

Connect the amplifier output to these terminal using a speakON NL4 cable wired 1+ 1-. This will power the GH8 speaker.

B) Terminals 2+ and 2-:

These terminals are not wired internally but serve as pass-through connections.

Use these terminals to connect additional GH8 speakers or similar units. Connect the next speaker's speakON cable wired 1+ 1- to these terminals. This allows the audio signal to continue to the next speaker.

The connection of multiple speakers in parallel is therefore facilitated by the pass-through feature of the second NL4 connector.

SpeakON		GH8	
A	1	1+ 1-	SIGNAL / IN
		2+ 2-	Trough / LINK OUT
B	2	1+ 1-	SIGNAL / IN
		2+ 2-	Trough / LINK OUT

1+1- SIGNAL IN

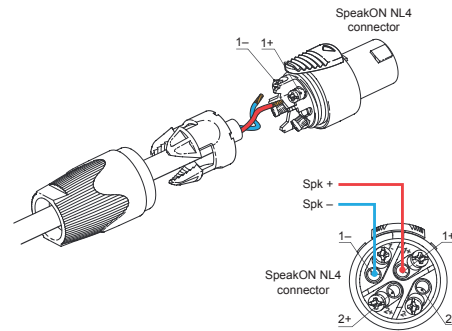

## Wiring with Euroblock 4-pin connector

The GH8 speaker also features a 4-pin Euroblock connector for quick and secure wiring in installation systems. This 4-pin Euroblock connector functions similarly to the two speakON NL4 connectors. The speaker is wired to the first two pins

- PIN1 / (1+) positive terminal
- PIN2 / (1-) negative terminal
- PIN3 / (1+) positive terminal - relaunch
- PIN4 / (1-) negative terminal - relaunch

PIN3 and PIN4 are used to pass the signal to another similar speaker connected in parallel and powered by the same amplifier.

16 Ω		
PIN 1	●	SIGNAL + (1+)
PIN 2	●	SIGNAL - (1-)
PIN 3	●	SIGNAL + (1+)
PIN 4	●	SIGNAL - (1-)

### Amplifier Channel Matching

After correctly setting the impedance value for your audio system, ensure it is connected to the suitable KGEAR or K-array amplifier unit. For parallel connection of multiple units, please consult the provided table at the following link. - [KGEAR amplifier to KGEAR speaker Matching Table](#). Please remember that the parallel connection lowers the total load impedance. Ensure that the combined impedance of all connected speakers matches the impedance rating supported by your amplifier to prevent overloading and potential damage.



KGEAR-to-KGEAR



K-array-to-KGEAR



Always check the loudspeaker impedance before connecting the amplifier.

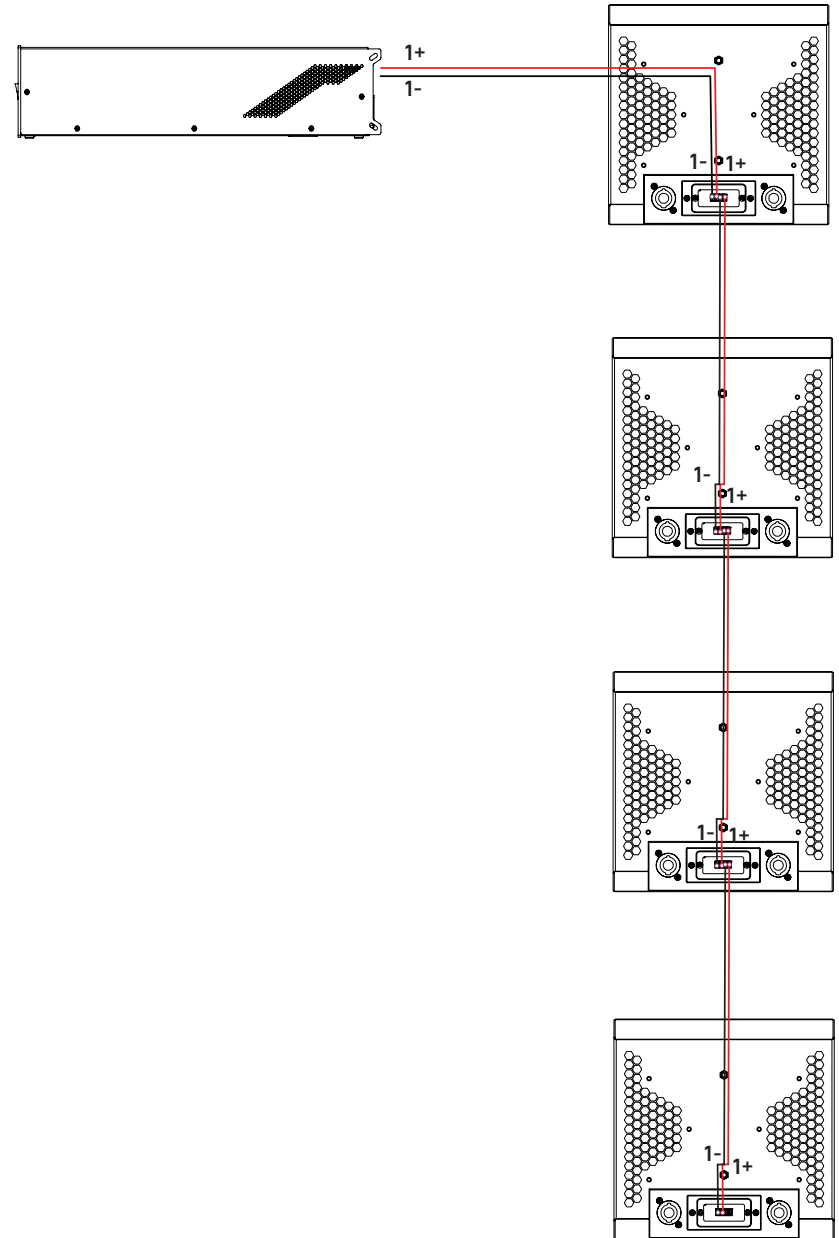
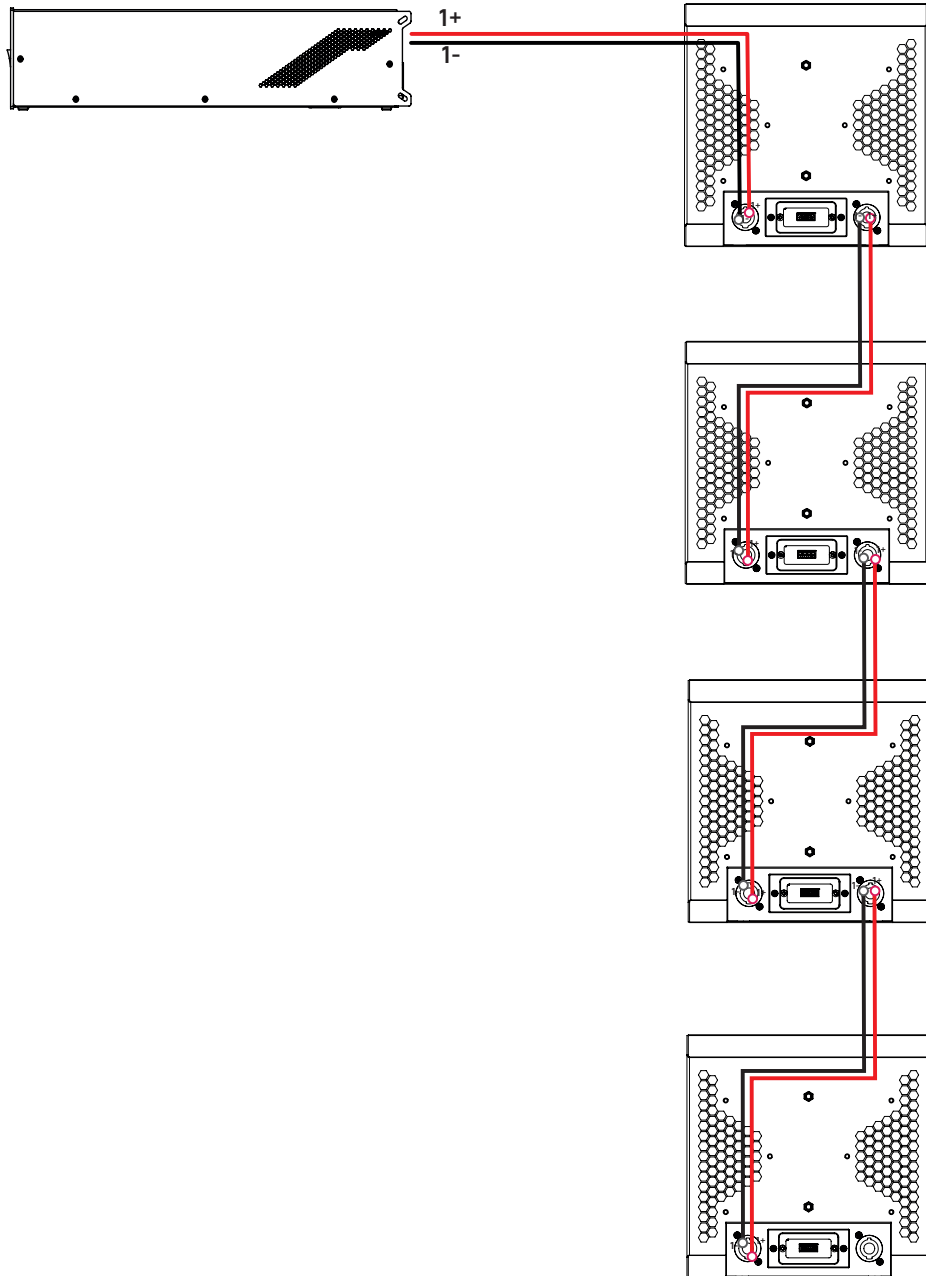

## Installation

### GH8UBRACKET mounting bracket

The GH8 speaker can be installed on the ceiling, wall, or floor using the GH8UBRACKET. This bracket is specifically designed to offer installation flexibility and features lateral holes that allow for various tilt angles. This functionality enables precise adjustment of the speaker's orientation and aiming, ensuring it is tailored to the listening area's needs and optimizing the desired acoustic coverage. As a result, it ensures effective sound diffusion across different spaces, meeting specific installation and listening requirements.

- 210° rotational freedom: Upward and downward movement.
- The GH8-UBRACKET is equipped with two different tilt points. By securing the bracket at the desired angle using the innermost points, greater tilt flexibility is achieved.
- **Installation tip:** For wall mounting or upward orientation, rotate the bracket 180° before attaching it to the speaker. This allows free downward movement.
- **Upward-facing setup:** In a theater setting, placing upward-facing speakers on the balcony is a fantastic way to cover higher seating areas, ensuring that sound reaches all listeners without blocking sightlines to the stage.

1

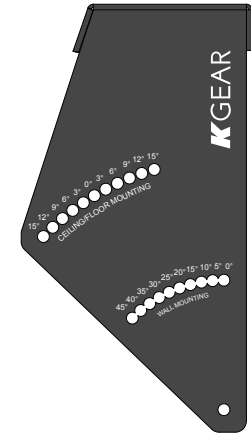
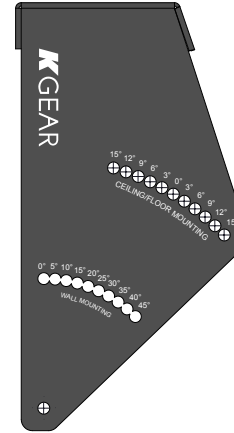

### GH8UBRACKET

1x GH8-UBRACKET

4x screws (included in the GH8-WALL accessory package.)

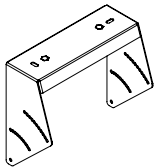

In the illustrations, we present various options for tilting and rotating the bracket. This system offers numerous combinations, adaptable to different applications and coverage areas. The various possible angles are clearly marked on the bracket's silkscreen, providing precise reference points to assist in achieving the desired positioning. We encourage you to explore all potential configurations, including those not depicted in the manual, for both wall-mounted and ceiling-mounted installations, ensuring optimal performance and

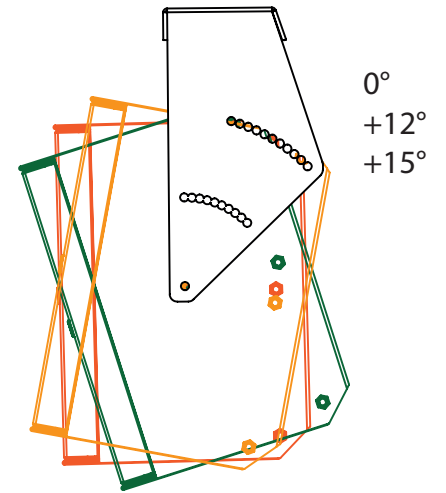
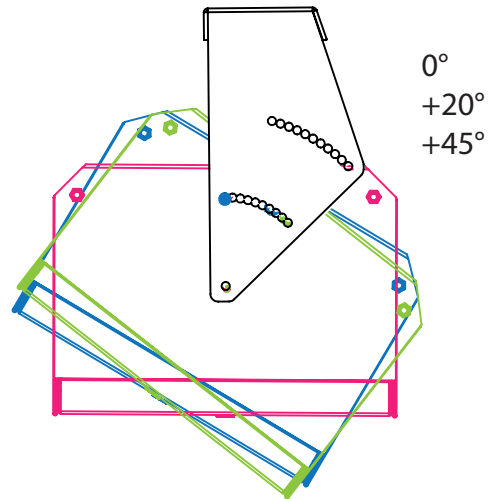
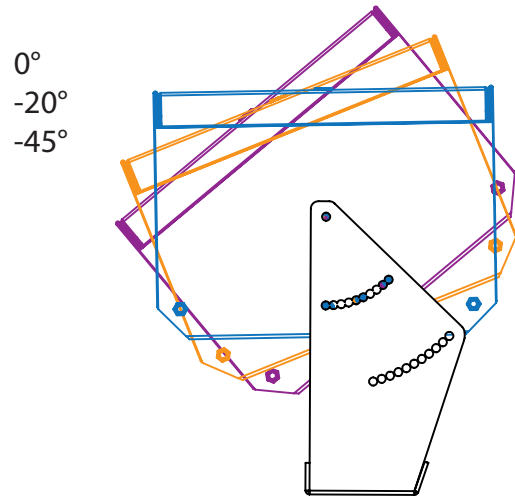
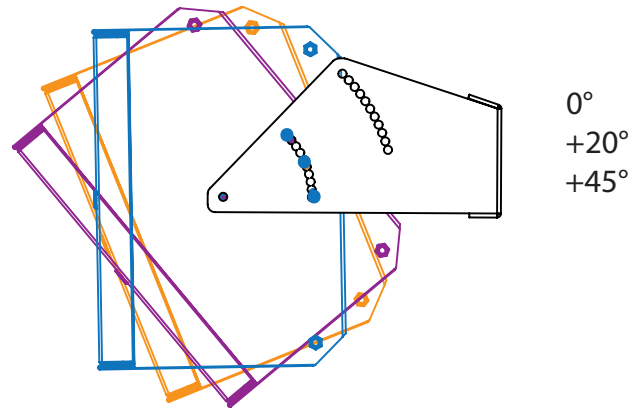
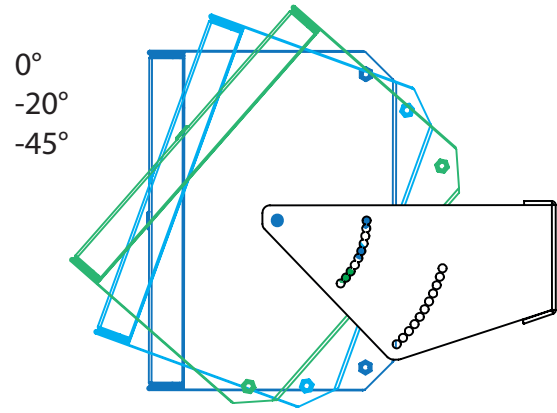

## Mini-array configuration

The GH8BRACKET allows for ceiling and floor installations of up to 2x GH8 units joined together using 2x GH8JOINTS. This configuration makes it easy to create small arrays, which can also be distributed throughout the space, without the need for the GH8FLY, which is designed for more complex setups in concert environments

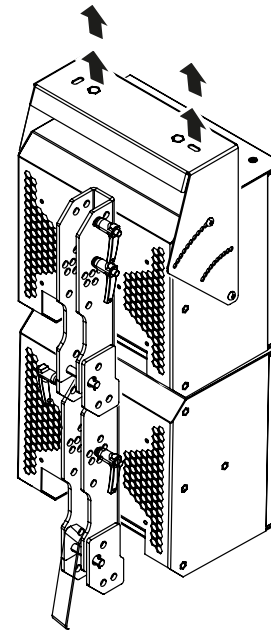
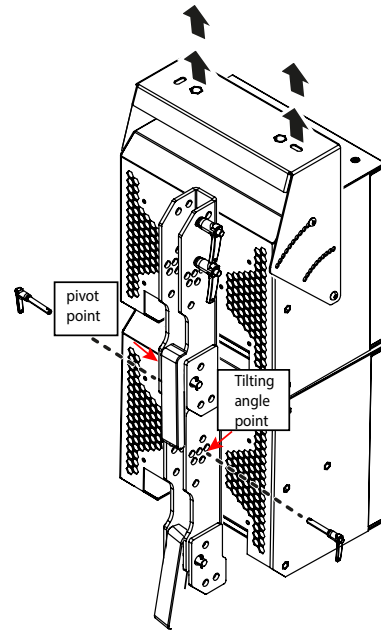

# GH8

flexibility to meet your specific needs.

To install the GH8 with the dedicated GH8-UBRACKET on ceiling please follow this steps:

1. Choose the desired installation location (ceiling or wall) and ensure that the surface is sturdy and can support the weight of the speaker and the bracket.
2. Make sure you have all necessary tools, such as a drill, screws, anchors, and a screwdriver.
3. Align the GH8-UBRACKET with the mounting points on the speaker.
4. Attach the bracket to the speaker using 2x of the 4x included screws to be fixed in the lateral mounting holes. The orientation holes should be left free at this stage.
5. Hold the speaker (with the bracket attached) in the desired position against the wall or ceiling.
6. Use a pencil to mark the drilling points through the bracket's mounting holes onto the wall or ceiling surface.
7. Drill the holes at the marked points.
8. Insert wall anchors if needed, especially if mounting on drywall or a ceiling for extra stability.
9. Secure the bracket (with the speaker attached) using screws. Do not tighten the screws completely yet, as you will need to adjust the angle.
10. After the speaker is mounted on the ceiling or wall, the screws in the orientation holes can be tightened. This allows for adjustment of the speaker's angle directly from the listening position.
11. Complete the process connecting and wiring the speaker to the amplifier
12. After the speaker is mounted on the ceiling or wall, the screws in the orientation holes can be tightened. This allows for adjustment of the speaker's angle directly from the listening position

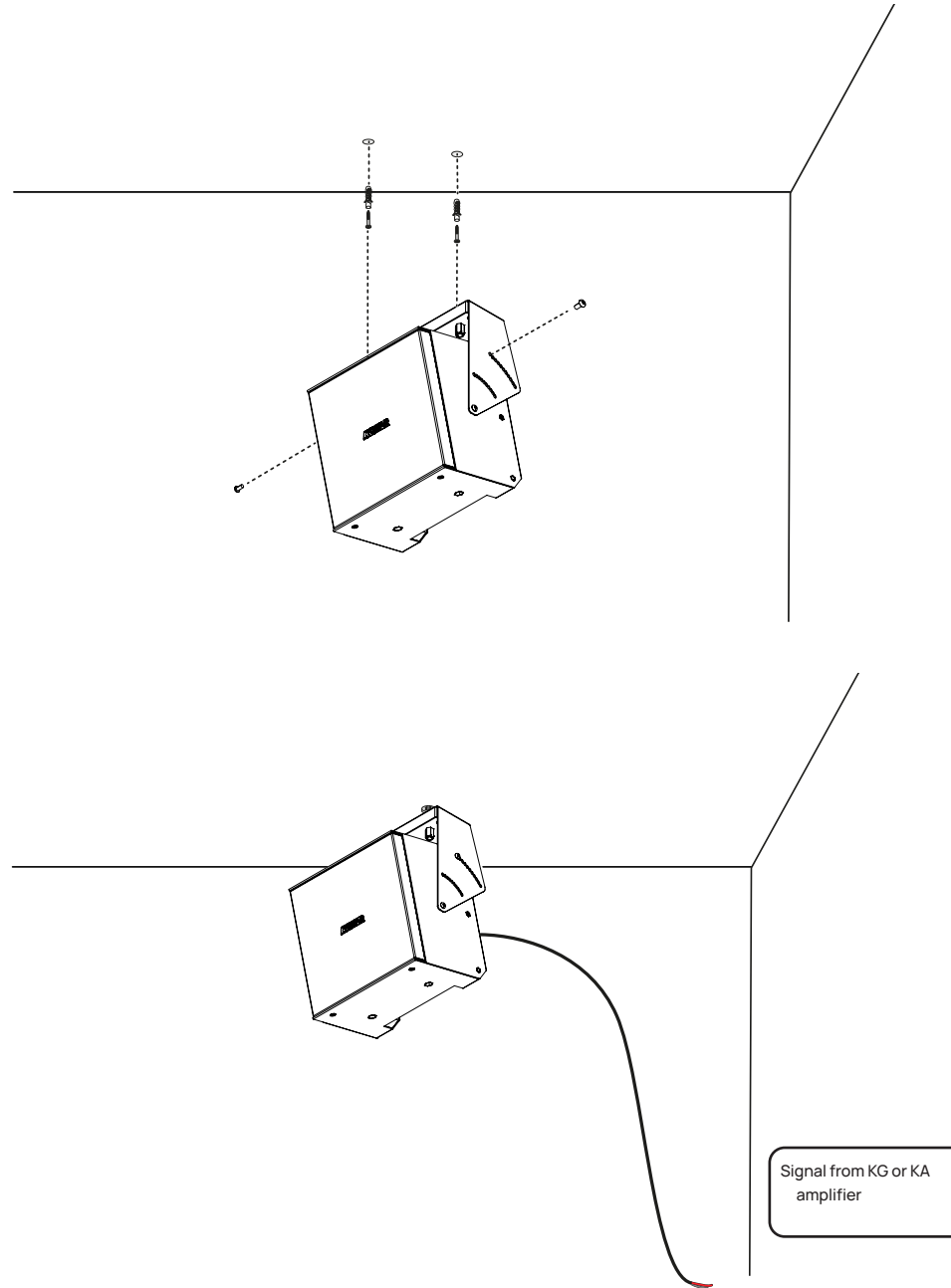

**GH8 + K-WALL2LMINI**

**Installation on wall - maximum inclination and tilting**

The K-WALL2LMINI is a miniature bracket derived from the larger K-WALL2L model by K-array™. This bracket is designed for wall and ceiling installation of an audio source and allows the speaker to be tilted downward up to 90°. Despite its small size, the K-WALL2LMINI retains the functionality of the larger model, offering a compact solution for securely mounting speakers while providing the option to direct the sound towards the audience or the desired area. The standout feature of the K-WALL2LMINI is its ability to allow for an even greater tilt, and it can also be used for ceiling installations. This added flexibility makes it an ideal choice for various setups, providing more options for precise sound direction and versatile mounting configurations.

**Installation:**

First, disassemble the K-WALL2L by removing the bottom screw of the bracket to be fixed on the

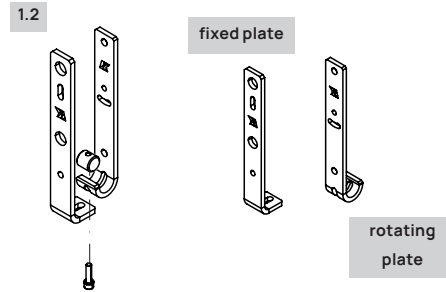

surface. The bracket's plate with the flatter end is the one that gets mounted on the wall, acting as the base for the other bracket (speaker side). Thanks to a freely rotating washer, the second bracket allows the speaker to be easily tilted to the desired angle.

1. First, determine the ideal position for mounting the speaker on the wall, considering both the height and distance relative to the area you want to cover and properly sound.
2. Mount the plate to the wall using two screws and anchors, spaced 60mm apart
3. After the plate has been mounted on the wall, the other plate should be secured to the speaker using the provided mounting screws.
4. Then, reattach the bracket to the wall-mounted plate, and if needed, adjust the speaker to the desired angle.
5. GH4 is installed on wall with the K-WALL2LMINI bracket accessory.

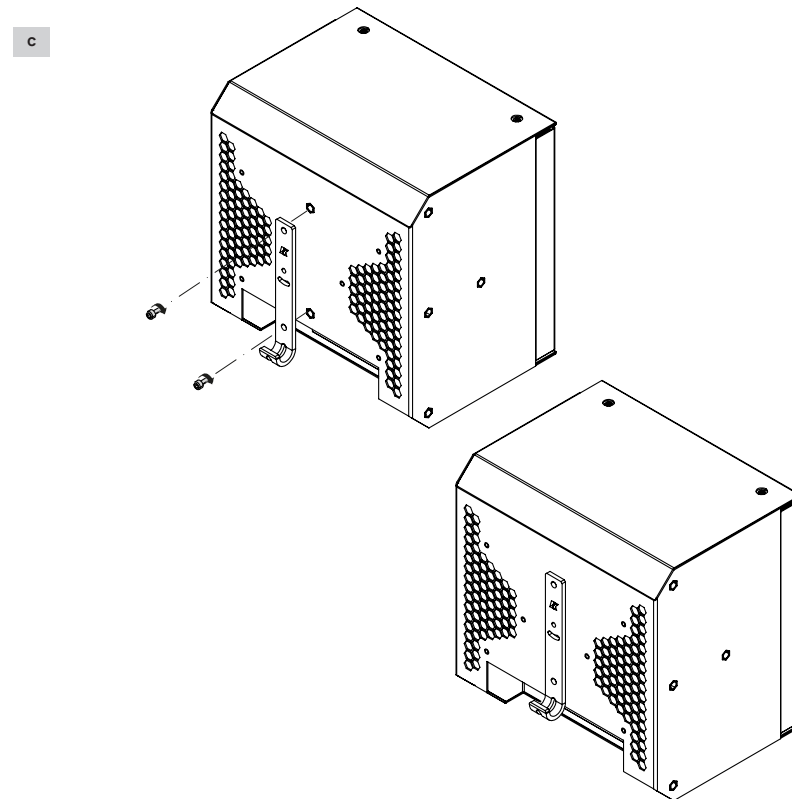
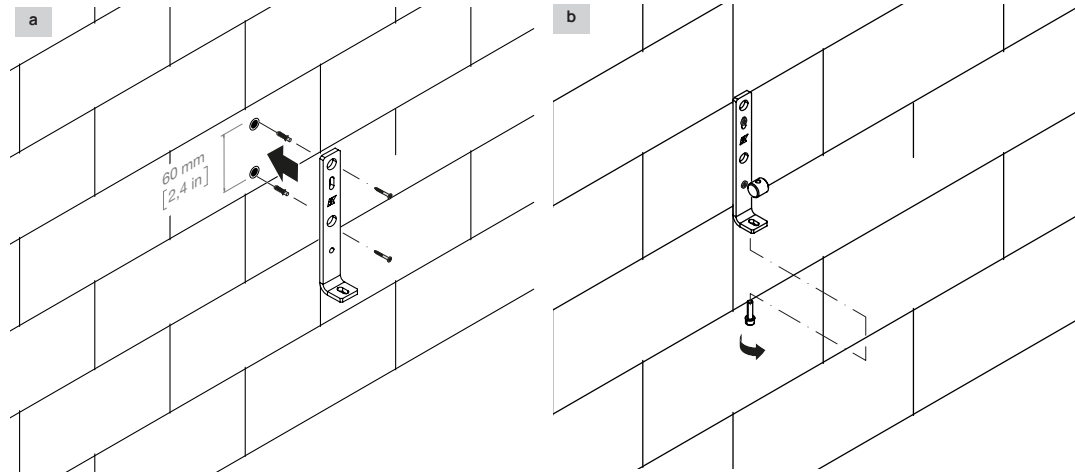
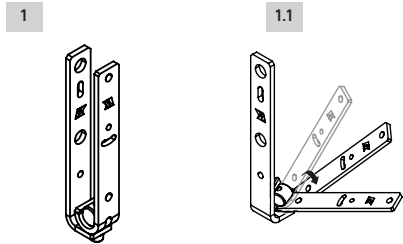



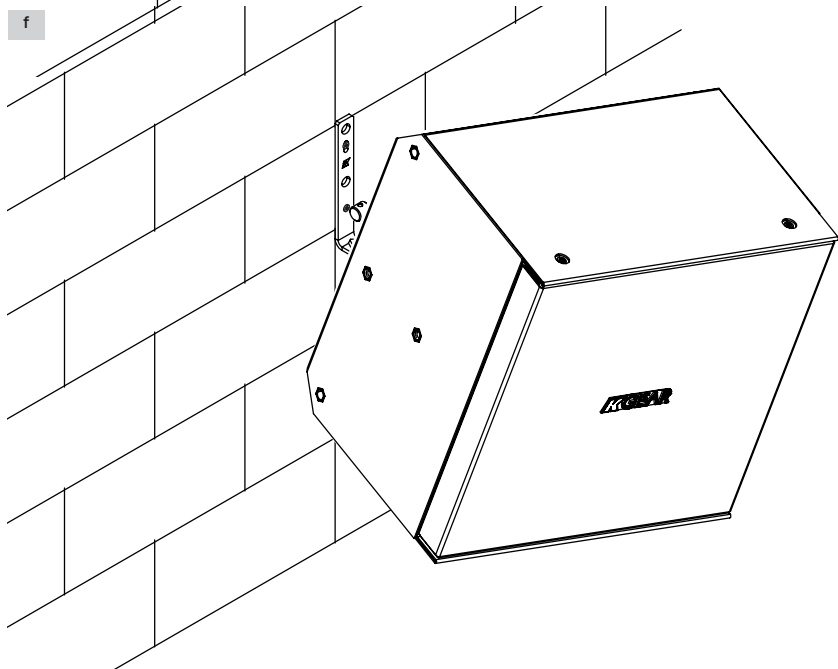
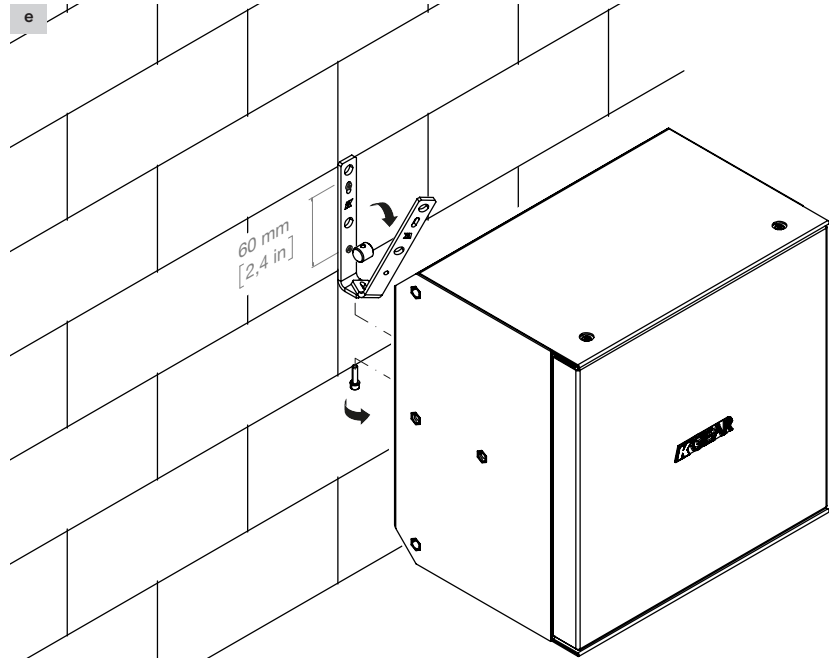
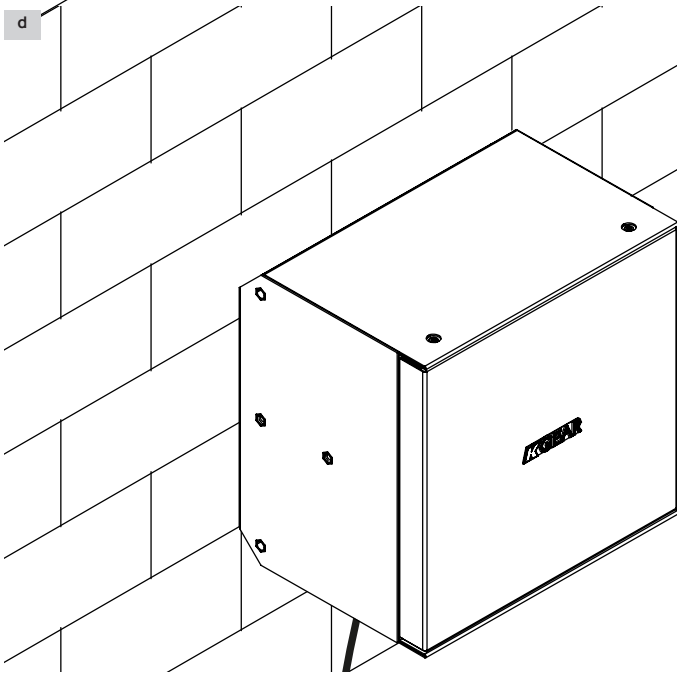
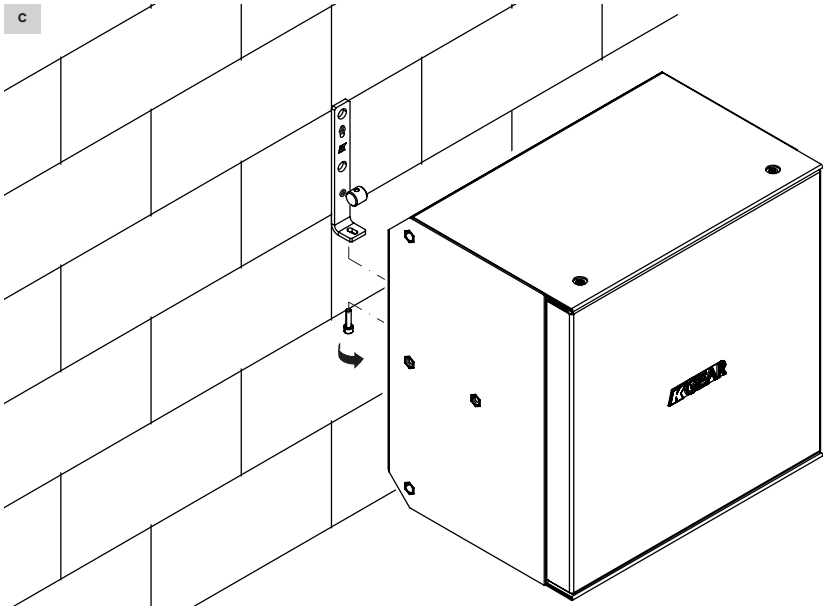

## GH8 + K-WALL2

The K-WALL2 is a variable tilt bracket by K-array™, designed for wall mounting an audio source. This support allows the speaker to be tilted downward and adjusted laterally, to the right and left, thanks to a small mobile arm that connects the bracket fixed to the wall with the one fixed to the speaker.

The K-WALL2 consists of:

- 2 brackets (one to be fixed to the wall and one to the speaker)
- 1 connecting arm to allow tilting and lateral adjustment
- Fixing screws for a secure and stable installation.

## Installation on wall

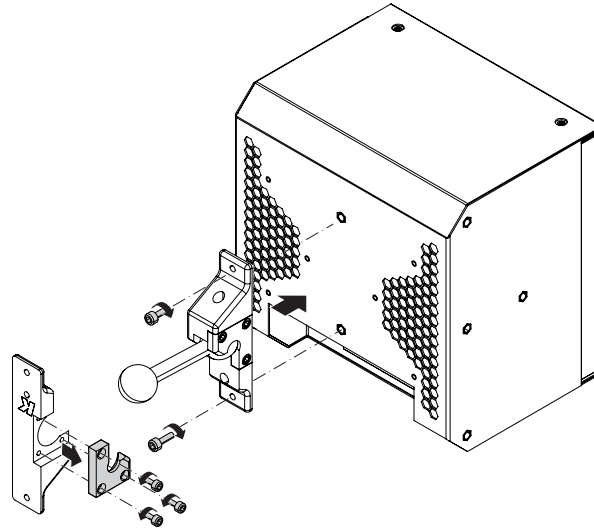
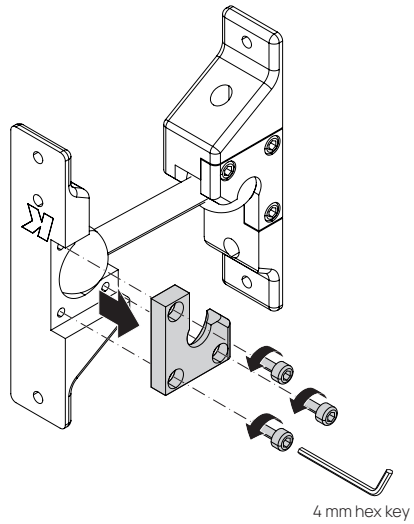

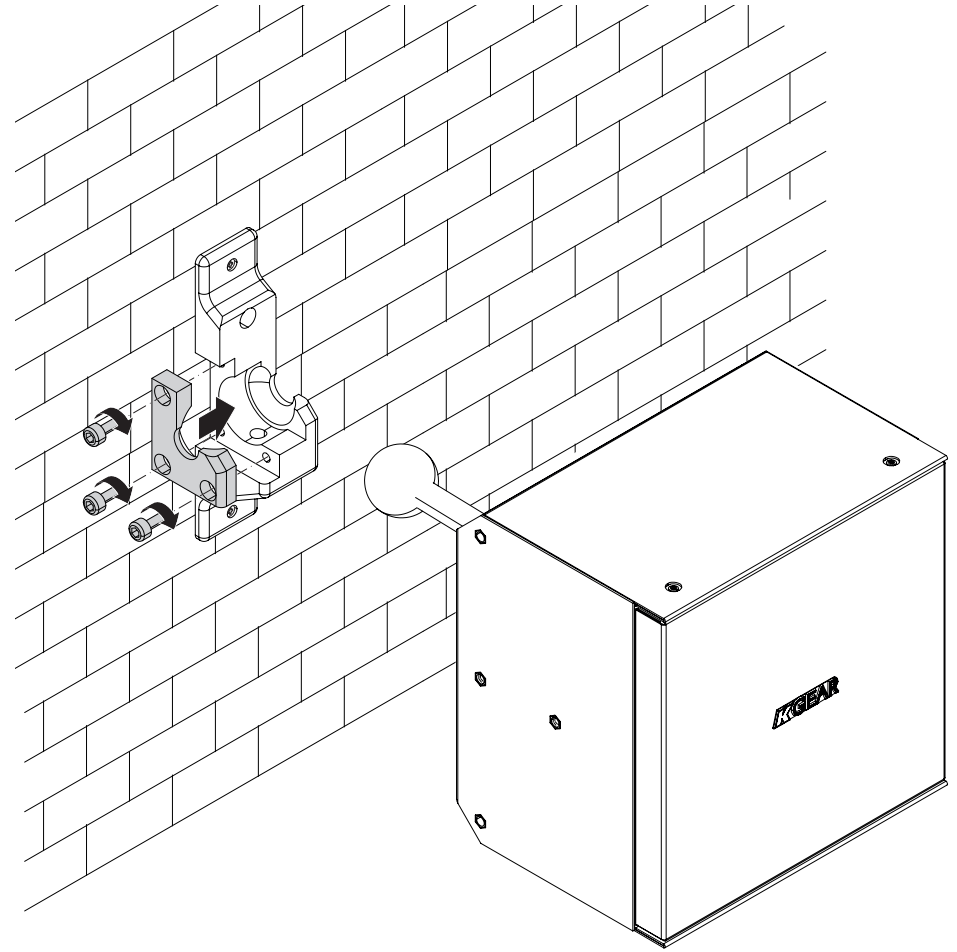
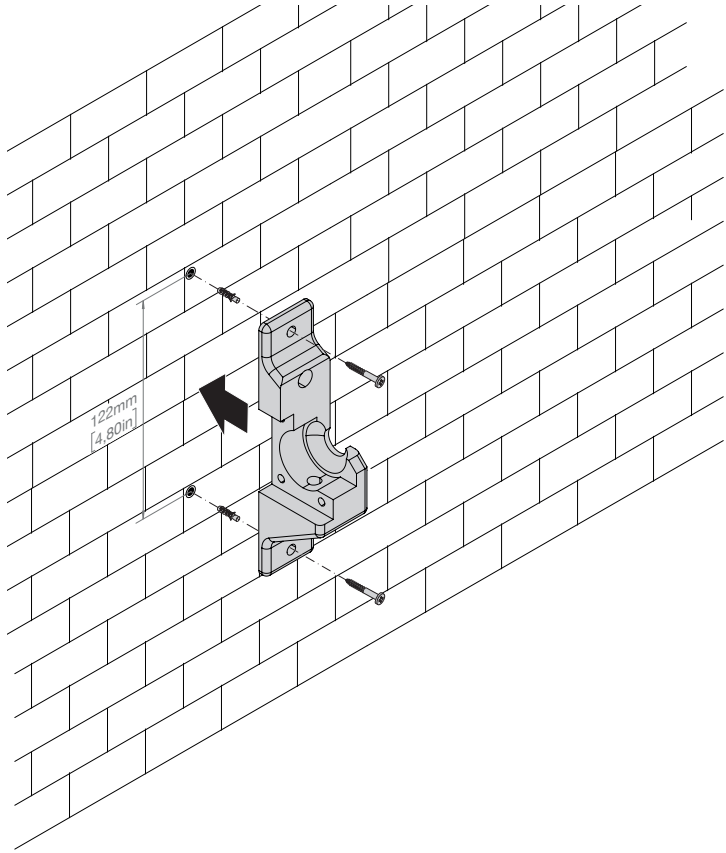

GH8

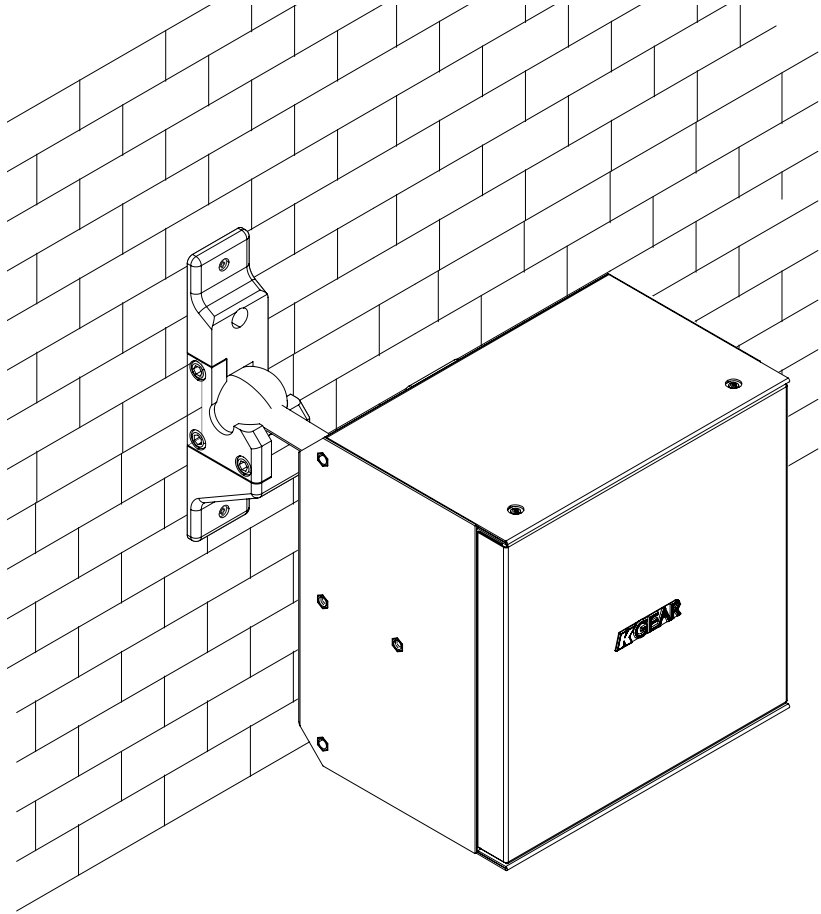

## Suspending longer arrays

### Kit for GH8 in array configuration GH8-FLY + GH8-JOINT

The GH8 is a modular unit that can be connected to other identical components to create extended arrays. The installation process begins by suspending the first unit using the specialized bumper hardware, which is designed to support the entire array. Once the initial unit is securely in place, additional units are connected sequentially using purpose-built joints, ensuring a stable and secure attachment while maintaining the array's suspension.

To suspend and connect different elements together and the entire array, first be sure to collect all the hardware components included in the accessory kit for GH8-FLY and GH8-JOINT:

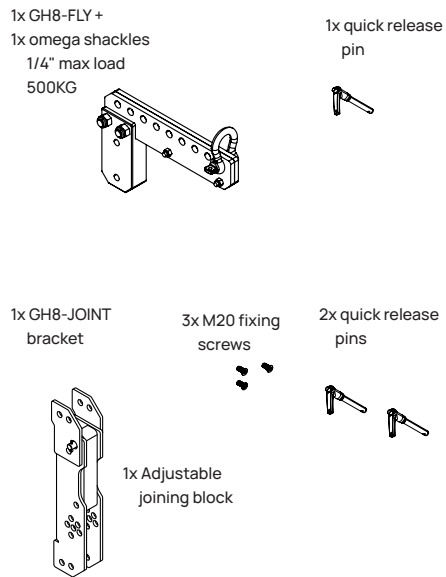

GH8-FLY and GH8-JOINT specifically designed and tested to support and suspend the weight of up to 12 consecutive units.

### Connecting Additional Units and Adjusting the Angle

#### GH8 Array Installation Procedure

1. Attach the Joining Bracket: Firmly screw the GH8-JOINT bracket to the side panel of the first module using the three M5x20 screws provided.
2. Using the dedicated quick release pin to fix the GH8-FLY to the GH8-JOINT attached to the first module
3. Partially Suspend the First Module: Slightly lift the first module to facilitate subsequent connection operations.
4. Joining Procedure for Each Module:
5. Connect Modules: Use the adjustable block to connect the next module to the previous one, ensuring that the joints are well aligned.
6. Adjust Inclination Angle: Set the desired inclination angle for each module, using the adjustable block.
7. Secure Inclination Points: Lock the inclination points with the quick-release pins to ensure that the speakers are fixed at the desired angle.
8. Check: Visually check that all joints are secure and that the modules are aligned correctly.
9. Wiring: Once the array structure is complete, proceed with wiring all modules according to the provided electrical diagrams. Ensure that the connections are secure and that the cables do not interfere with the movement of the array.
10. Gradual Lifting of the Array: Gradually lift the entire array to the desired height, ensuring that each module is well supported and that the system is stable.

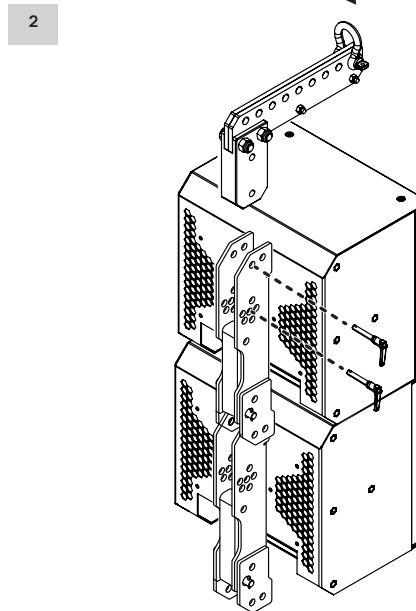
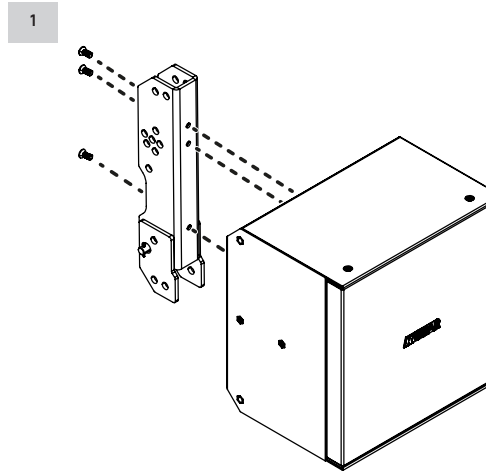

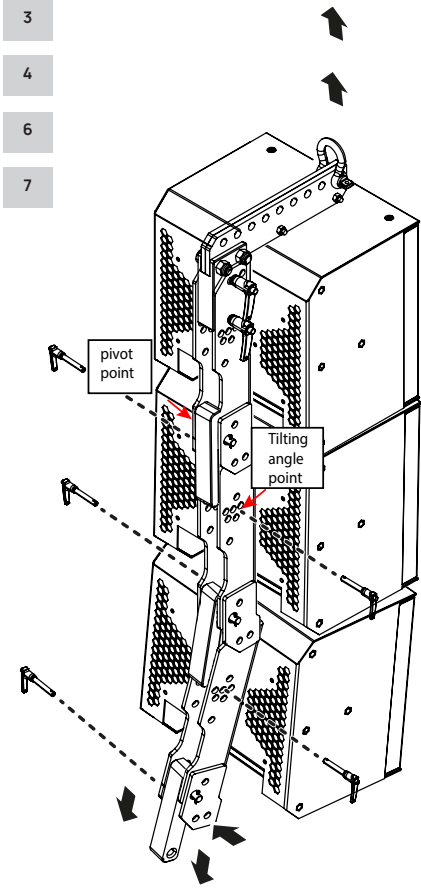

fix the quick quick release pin here to fix the GH8-FLY to GH8-JOINT

...and here

fix the quick quick release pin here to join next GH8-JOINT and GH8

fix the quick quick release pin here to join next GH8-JOINT and GH8 for down-tilt array configuration



8

9

## GH8 UPTILT ARRAY CONFIGURATION

The GH8-FLY can be mounted to the last element of the array, providing an additional rigging point on the back for enhanced flexibility. By securing the joint pin to the pull-back point marked on the silkscreen, the array can be lifted while enabling downward tilting of the loudspeakers. This configuration is particularly effective for setups that need to cover both elevated areas, such as bleachers or side sections, and downward areas closer to the stage.

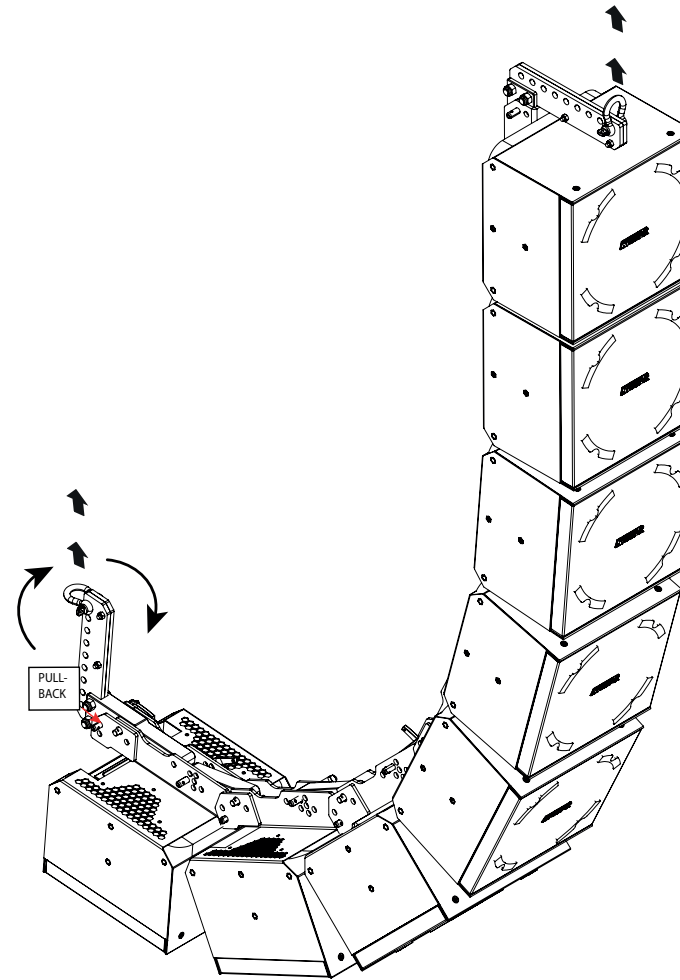
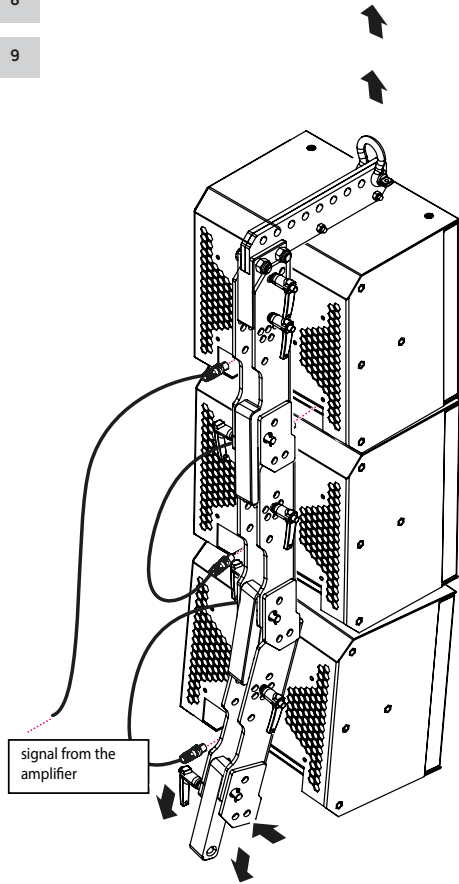

## GH8

The GH8FLY can be installed rotated by 180° (flipped) on the first element of the array. This reversed installation creates a rear rigging point, which can then be used as a pull-back point.

A pull back point It provides additional control to tilt the array backward, ensuring the sound dispersion matches the venue's requirements.

It helps stabilize the array by applying tension from the rear, especially in scenarios where the array needs to compensate for specific mounting constraints.

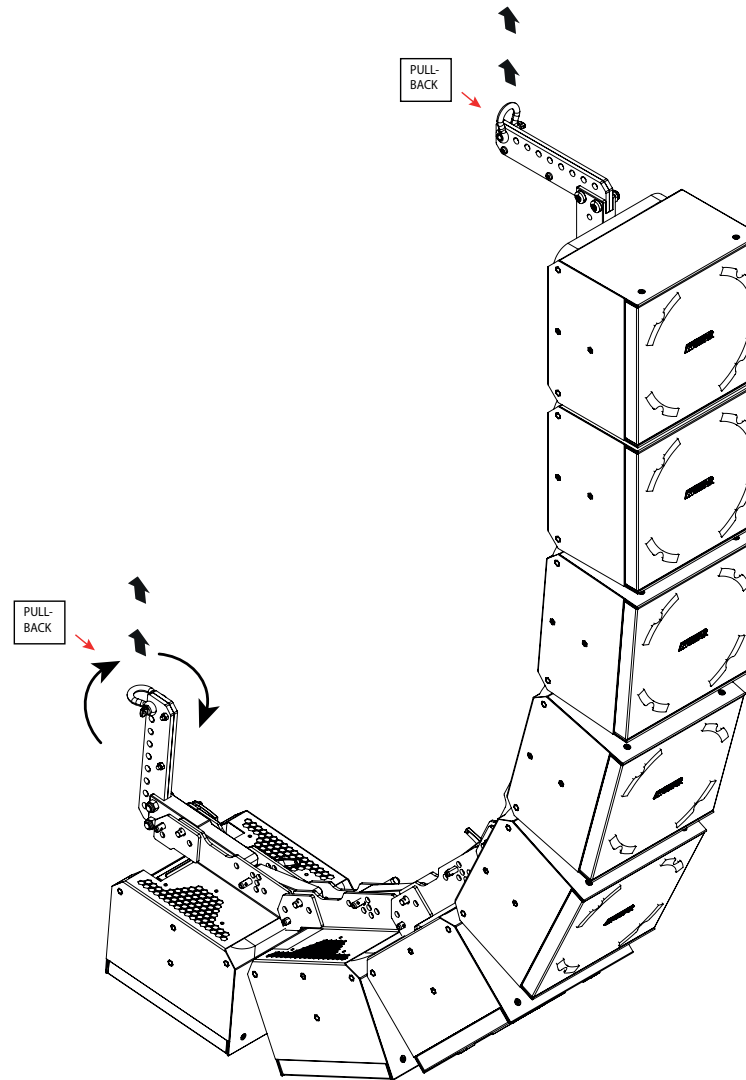



## Standard Pole Mounting

### GH8-WALL + Standard pole mounting flange

The GH8 with GH8-WALL bracket can be easily installed on any standard commercial pole mounting flange, thanks to its bracket with standardized spacing holes, ensuring compatibility with commercial-grade flanges

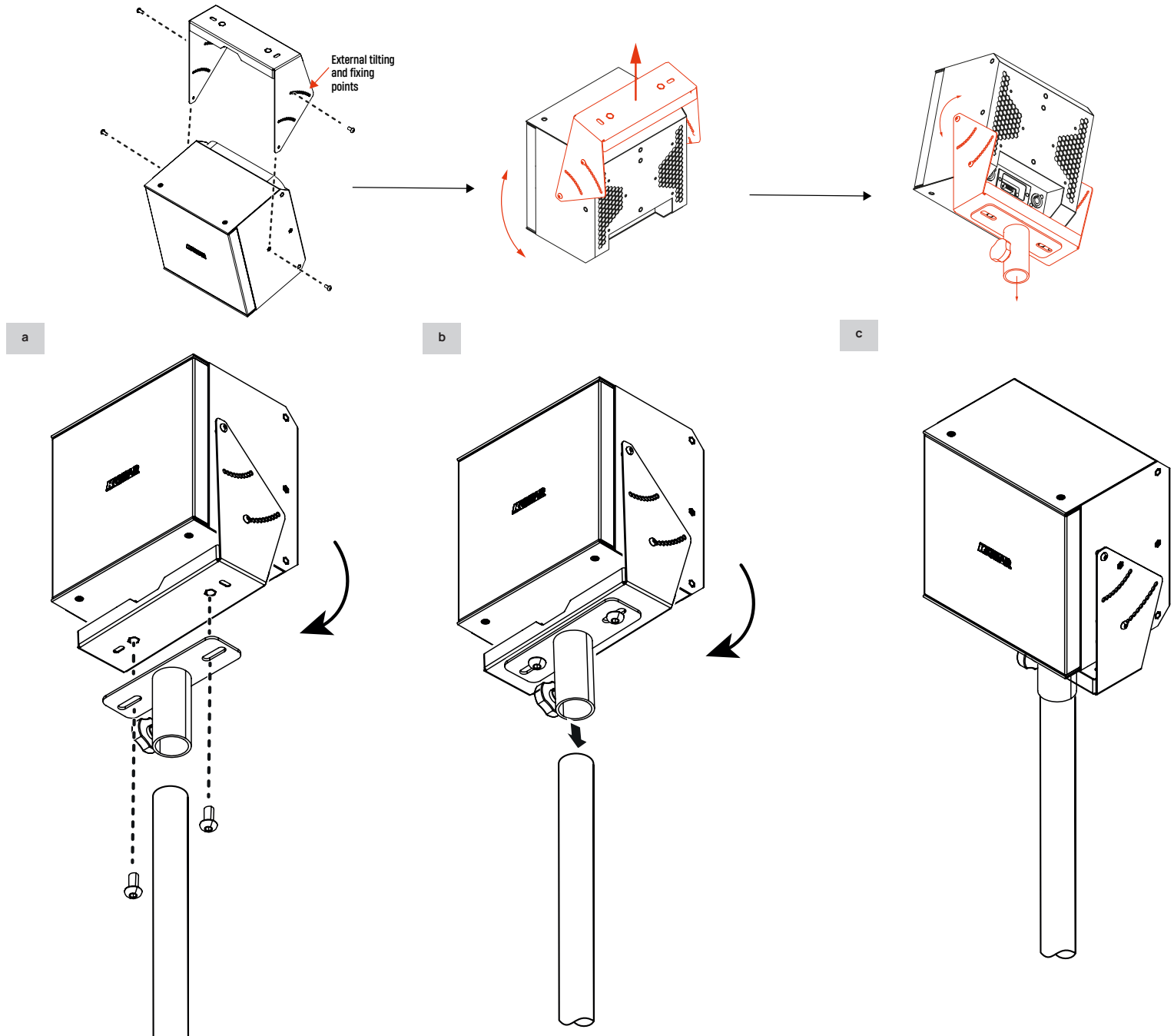

## Dedicated Pole mounting

### G-POLEMOUNT1

The G-POLEMOUNT1 is an accessory designed for mounting the GH8 speaker on a standard pole, allowing for an adjustable tilt of +90° to -90°.

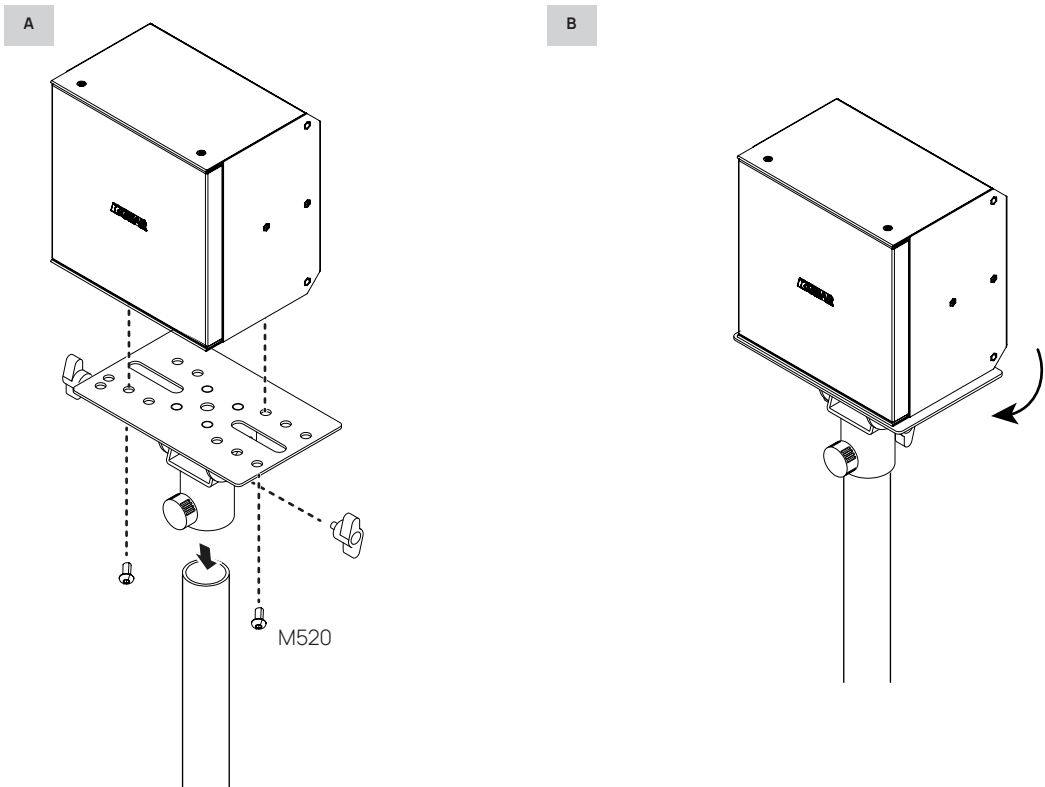

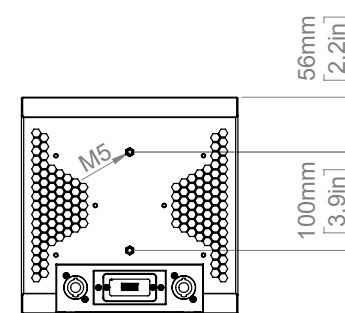
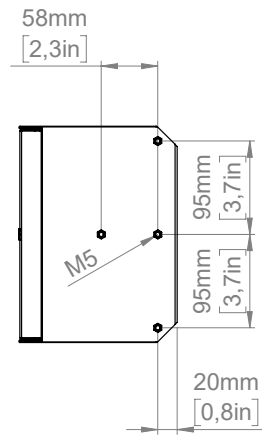
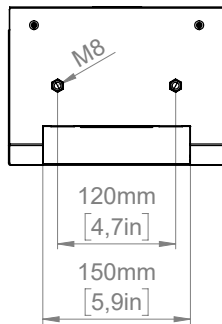
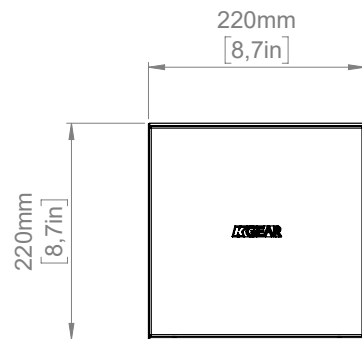
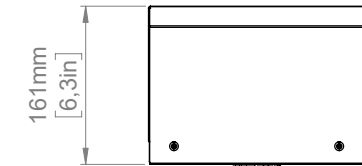

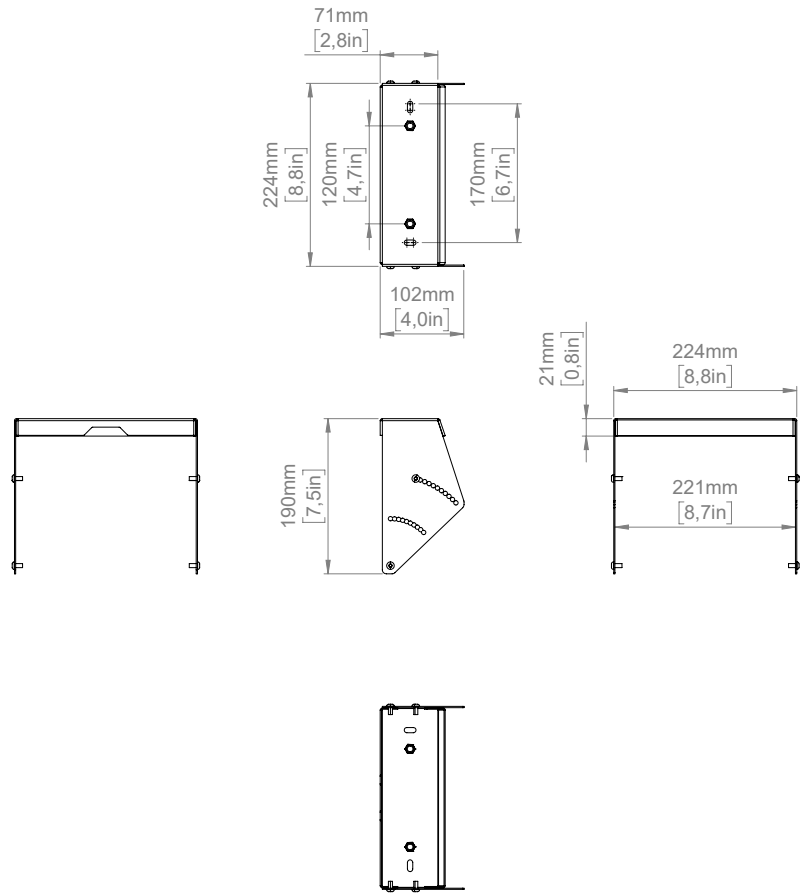

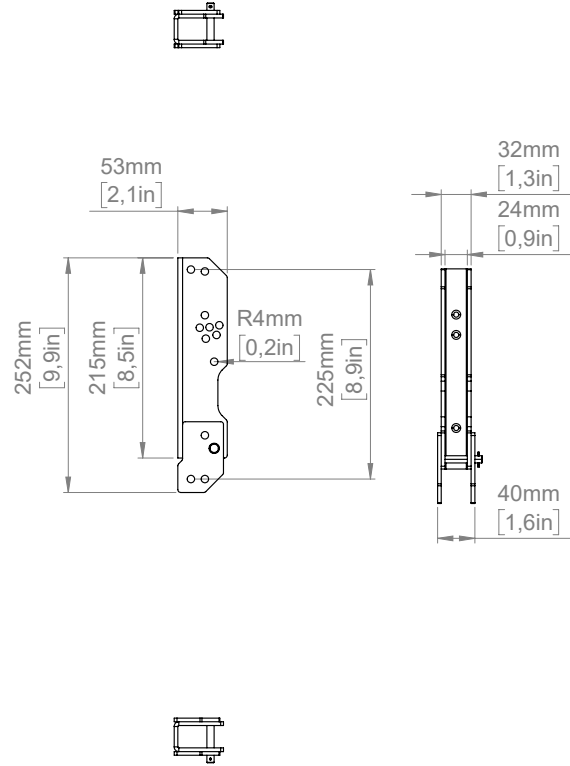

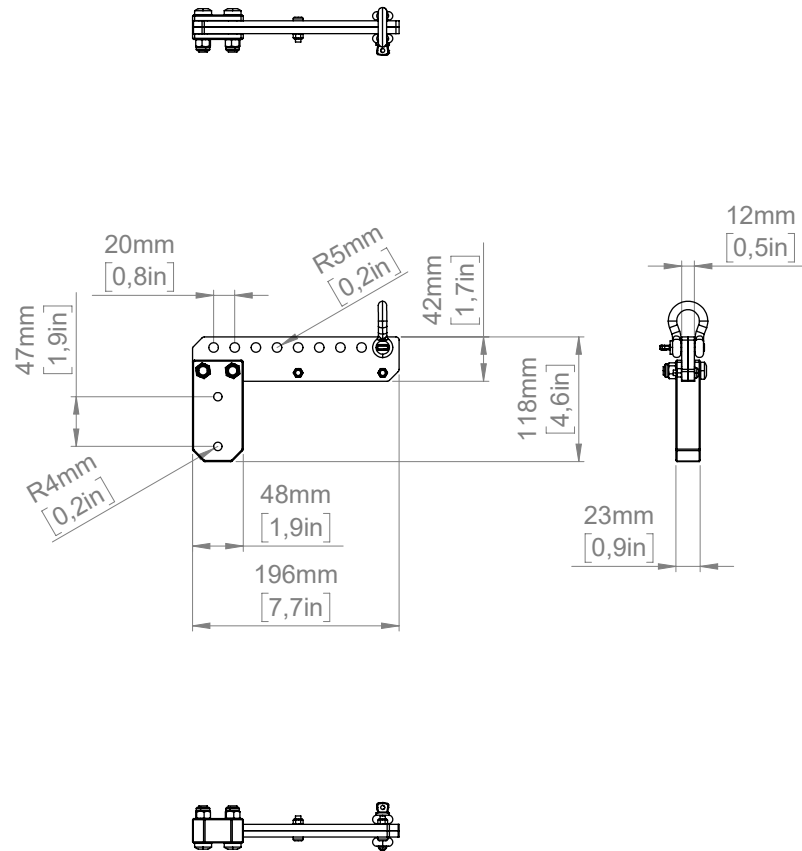



**IMPORTANT SAFETY INSTRUCTIONS**

 **CAUTION**  
RISK OF ELECTRIC SHOCK  
DO NOT OPEN



**ATTENTION** RISQUE DE CHOC ELECTRIQUE NE PAS OUVRIR

---

**CAUTION:** TO REDUCE THE RISK OF ELECTRIC SHOCK,  
DO NOT REMOVE COVER (OR BACK).  
NO USER-SERVICEABLE PARTS INSIDE.  
REFER SERVICING TO QUALIFIED SERVICE PERSONNEL.



This symbol alerts the user to the presence of recommendations about the product's use and maintenance.



The lighting flash with arrowhead symbol within an equilateral triangle is intended to alert the user to the presence of uninsulated, dangerous voltage within the product enclosure that may be of magnitude to constitute a risk of electrical shock.



The exclamation point within an equilateral triangle is intended to alert the user to the presence of important operating and maintenance (servicing) instructions in this guide.



Operator's manual; operating instructions  
This symbol identifies the operator's manual that relates to the operating instructions and indicates that the operating instructions should be considered when operating the device or control close to where the symbol is placed.



For indoor use only  
This electrical equipment is designed primarily for indoor use.



WEEE  
Please dispose of this product at the end of its operational lifetime by bringing it to your local collection point or recycling center for such equipment.



This device complies with Restriction of Hazardous Substances Directive.



Warning. Failure to follow these safety instructions could result in fire, shock or other injury or damage to the device or other property.

General heed and warnings

- Read these instructions.
- Keep these instructions.
- Heed all warnings.
- Follow all instructions.
- Do not use this apparatus near water.
- Clean only with dry cloth.
- Do not block any ventilation openings. Install in accordance with the manufacturer's instructions.
- Do not install near any heat sources such as radiators, heat registers, stoves, or other apparatus (including amplifiers) that produce heat
- Only use attachments/accessories specified by the manufacturer.
- Clean the product only with a soft and dry fabric. Never use liquid cleaning products, as this may damage the products cosmetic surfaces.
- Use only with the cart, stand, tripod, bracket, or table specified by the manufacturer, or sold with the apparatus. When a cart is used, use caution when moving the cart/apparatus combination to avoid injury from tip-over. 
- Unplug this apparatus during lightning storms or when unused for long periods of time.
- Refer all servicing to qualified service personnel. Servicing is required when the apparatus has been damaged in any way, such as power-supply cord or plug is damaged, liquid has been spilled or objects have fallen into the apparatus, the apparatus has been exposed to rain or moisture, does not operate normally, or has been dropped.

**CAUTION:** These servicing instructions are for use by qualified service personnel only. To reduce the risk of electric shock, do not perform any servicing other than that contained in the operating instructions unless you are qualified to do so.

These apparatus are intended for professional use.

Installation and commissioning may only be carried out by qualified and authorized personnel.

**WARNING:** Only use attachments/accessories specified or provided by the manufacturer (such as the exclusive supply adapter, battery, etc.)

Use only speaker cables for connecting speakers to the speaker terminals. Be sure to observe the amplifier's rated load impedance particularly when connecting speakers in parallel. Connecting an impedance load outside the amplifier's rated range can damage the apparatus.

KGEAR will not shoulder any responsibilities for products modified without prior authorization.

**Service**

To obtain service:

1. Please have the serial number(s) of the unit(s) available for reference.
2. Contact the official KGEAR distributor in your country: or KGEAR headquarter at info@kgear.it. Please describe the problem clearly and completely to the Customer Service.
3. You will be contacted back for on-line servicing.
4. If the problem cannot be resolved over the phone, you may be required to send the unit in for service. In this instance, you will be provided with an RA (Return Authorization) number which should be included on all shipping documents and correspondence regarding the repair. Shipping charges are the responsibility of the purchaser.

Any attempt to modify or replace components of the device will invalidate your warranty. Service must be performed by an authorized K-array service center.

**Cleaning**

Use only a soft, dry cloth to clean the housing. Do not use any solvents, chemicals, or cleaning solutions containing alcohol, ammonia, or abrasives. Do not use any sprays near the product or allow liquids to spill into any openings.

Technical specifications
Type <b>Passive loudspeaker</b>
Transducer <b>8" ferrite magnet full-range dual cone transducer</b>
Frequency Response <sup>1</sup> <b>120 Hz - 18 kHz (-6dB)</b>
Max SPL <sup>2</sup> <b>129 dB Peak</b>
Power Handling <b>300 W</b>
Coverage <b>V.90   H.90°</b>
Connectors <b>1x Phoenix connector (4-pin Euroblock) with speaker relaunch 2x SpeakOn NL4 1+ 1- (signal) 2+ 2- (trough)</b>
Nominal Impedance <b>16 Ω</b>
IP Rating <b>IP64</b>
Handling & Finishes
Dimensions (WxLxH) <b>220x 220 x 161 mm (8,7 x 8,7 x 6,3 inches)</b>
Weight <b>5,8 kg (14,3 lbs)</b>
Material <b>Stainless Steel</b>
Color <b>Black</b>

<sup>1</sup> With dedicated preset

<sup>2</sup> Maximum SPL is calculated using a signal with crest factor 4 (12 dB) measured at 8 m then scaled at 1 m

<sup>3</sup> More complete water protection with GH8-IPKIT accessory (not included).