



***Kobra***

***KK52 / KK52*** Mark I  
***KK102 / KK102*** Mark I

USER GUIDE  
English



WHAT'S NEW IN THE MARK I VERSION?

New paint work for black and white models, no screen printing of names and logos.

## TABLE OF CONTENTS

SYMBOLS .....	3
1. INTRODUCTION .....	4
2. KEY FEATURES .....	4
3. APPLICATIONS.....	4
4. SAFETY INFORMATION.....	5
5. UNPACKING .....	6
6. PHYSICAL.....	6
6.1 KK52 LAYOUT .....	6
6.2 KK102 LAYOUT .....	7
7. WIRING .....	8
7.1 IMPEDANCE SWITCH .....	8
7.2 COVERAGE SWITCH .....	9
8. ACCESSORIES AND CONFIGURATIONS.....	10
8.1 SUSPENDING FROM THE FLY-BAR .....	10
8.2 HANGING ON THE WALL .....	11
8.3 STANDING ON THE BASE .....	11
8.4 HORIZONTAL CLUSTER.....	12
8.5 GROUND LAYING.....	12
8.6 STANDING ON A KMT SUBWOOFER.....	13
8.7 OUTDOOR INSTALLATION .....	13
9. SERVICE .....	14
10. TECHNICAL SPECIFICATIONS .....	15
11. EN54-24 DATA .....	16

## SYMBOLS



K-array declares that this device is in compliance with applicable CE standards and regulations. Before putting the device into operation, please observe the respective country-specific regulations!

---



Waste Electrical and Electronic Equipment (WEEE)  
Please dispose of this product at the end of its operational lifetime by bringing it to your local collection point or recycling center for such equipment.

---



This symbol alerts the user to the presence of recommendations about the product's use and maintenance.

---



Warning: DANGEROUS VOLTAGE.  
Terminals marked with this symbol carry a risk of electric shock, therefore external wiring connected to these terminals requires installation by a qualified professional or the use of ready-made leads or cords.

---



This symbol alerts the user to the presence of recommendations about product's use and maintenance.

---



This device complies with the Restriction of Hazardous Substances Directive.

---

## 1. INTRODUCTION

The K-array Kobras are passive speaker systems, comprised of 2" neodymium magnet transducers housed in an elegant and sturdy stainless steel chassis. Available in two lengths, the KK52 features 8 drivers in a 0.5 m (19.6"), while the KK102 features 16 drivers in a 1 m (39.4") chassis.

The Kobra's closely spaced cone drivers provide phase coherence, low distortion and focused listening both up close and at a distance.

To accommodate a range of applications, the vertical dispersion pattern can be switched for either wide or narrow coverage.

Optional rigging and linking accessories allow multiple speakers to be interconnected, creating a wide array of vertical and horizontal configurations for temporary or permanent installation.

For integration with other speakers or amplifiers, the KK52 and KK102 offer selectable impedance (16 $\Omega$ /64 $\Omega$  for the KK52 and 8 $\Omega$ /32 $\Omega$  for the KK102).

Kobras are able to reproduce the entire vocal frequency range with excellent intelligibility, starting from 150 Hz.

Integrating powered K-array subwoofers (KMT12, KMT18, KMT21) ensures excellent coverage of the entire musical frequency range. K-array's KA amplifier series also features custom presets, optimized for use with the Kobra series.

All Kobra components are designed by K-array and custom-made under K-array's quality control system.

## 2. KEY FEATURES

- Unique performance-to-size ratio
- Vertical, Horizontal and 3D line-array applications
- Multiple 2" long-excursion full-range cone drivers
- Wide horizontal coverage
- Selectable vertical pattern (Spot/Flood)
- Electronically protected
- Selectable impedance (KK52: 16/64  $\Omega$ , KK102: 8/32  $\Omega$ )
- Weatherproof, suitable for outdoor installations - IP54

## 3. APPLICATIONS

- Theatre, club, house of worship
- Front fill and under-balcony fill
- Portable and installed AV systems
- Stage and AV studio monitoring

## 4. SAFETY INFORMATION



Warning: failure to follow these safety instructions could result in injury or damage to the device or other property.

### IMPORTANT SAFETY INSTRUCTIONS

- Read these instructions.
  - Keep this instructions.
  - Heed all warnings.
  - Follow all instructions and keep all warnings.
  - Only use attachments/accessories specified by the manufacturer.
- 

  - Use only with the cart, stand, tripod, bracket, or table specified by the manufacturer or sold with the apparatus.
  - When a cart is used, use caution when moving the cart/apparatus combination to avoid injury from tip-over.
- **Avoiding hearing damage.** Professional loudspeakers are capable of producing extremely high sound levels and should be used carefully. Never stand close to loudspeakers driven at high volume. Set the volume to a safe level. You can adapt over time to a higher volume of sound that over time may sound normal but can be damaging to your hearing. Hearing loss worsens after exposure to a sound level of 90 dB or over for an extended period of time. If you experience ringing in your ears or muffled speech, stop listening and have your hearing checked. The louder the volume, the less time is required before your hearing could be affected.
  - **Choking Hazards.** This device contains small parts, which may present a choking hazard to small children. Keep the device and its accessories away from small children.
  - **Do not make repairs yourself.** Never attempt to disassemble, repair or modify the system yourself. Disassembling the unit may cause damage that is not covered under the warranty. The device contains no user-serviceable parts. Repairs should only be performed by factory trained service personnel.
  - **Sound distortion.** Do not operate speakers for an extended period of time with sound distortion. This is an indication of malfunction, which in turn can generate heat and result in a fire.
  - **Carrying, handling and installing the device.** The device contains sensitive components. Do not drop, disassemble, open, crush, bend, deform, puncture, shred, incinerate, paint, or insert foreign objects into it. If your device has been dropped or damaged unplug the power cable immediately.
  - **Set up.** Set up your device on a stable retaining horizontal surface. If combined or mechanically connected with other products, always verify the stability of the resulted system. Install the unit only in a location that can structurally support the weight of the unit and far away from people who can interfere with the stability of the system. Assure that the wind does not interfere with the system's stability, taking extra securities like chains, weights, ropes or any other certified anchoring systems. Doing otherwise may result in the unit falling down, causing personal injury or property damage or even death. The system should only be suspended by qualified personnel following safe rigging practices. Secure fixings to the building structure are vital. To clarify any doubt you may have, seek help from architects, structural engineers or other specialists.

## 5. UNPACKING

Each K-array speaker is built to the highest standard and thoroughly inspected before leaving the factory. Upon arrival, carefully inspect the shipping carton, then examine and test your new amplifier. If you find any damage, immediately notify the shipping company. Only the consignee may institute a claim procedure regarding the system's electronic equipment.

## 6. PHYSICAL

### 6.1 KK52 LAYOUT

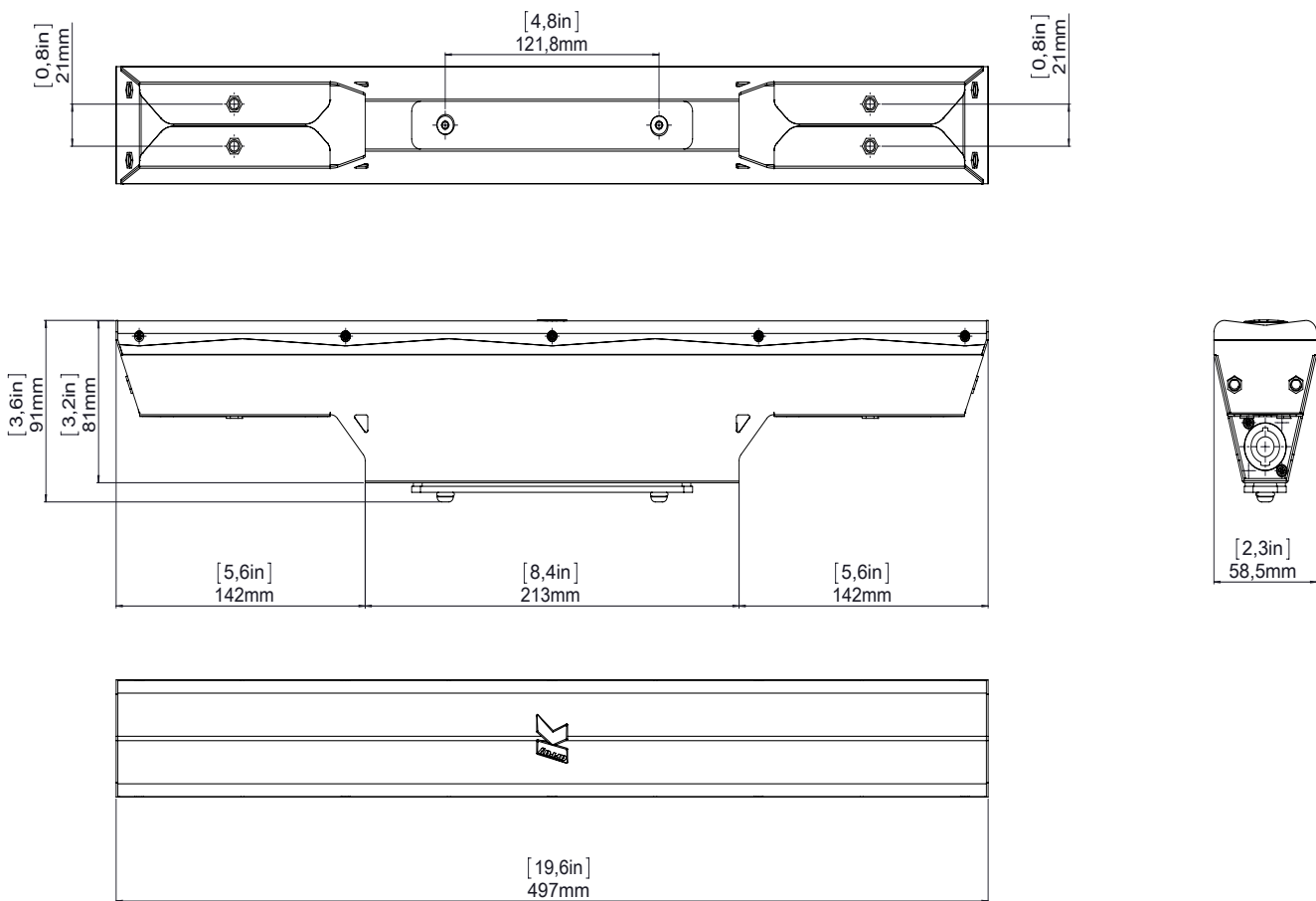

Weight  
2.3 kg (5.1 lbs)

### 6.2 KK102 LAYOUT

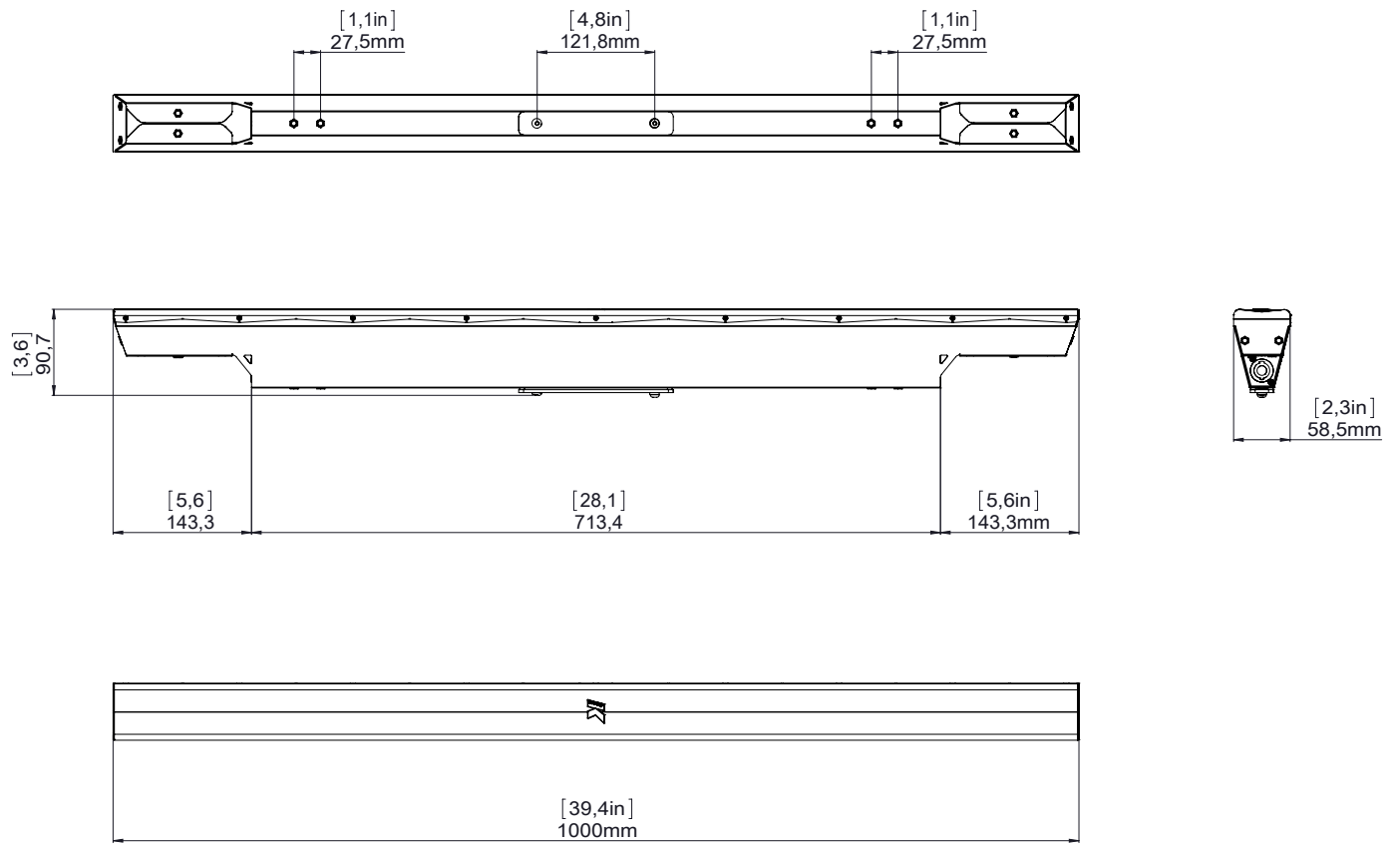

Weight  
4.6 kg (10.1 lbs)

## 7. WIRING

KK52 and KK102 internal wiring is designed to pick up audio power signal from pins 1+ / 1- of a Speakon NL4 connector. Pins 1+ and 1-, such as pins 2+ and 2-, are directly wired from one socket to the other, so the two sockets are equivalent and can be used to connect the speaker to the amplifier or to connect the speaker to another one driven in parallel by the same amplifier channel.

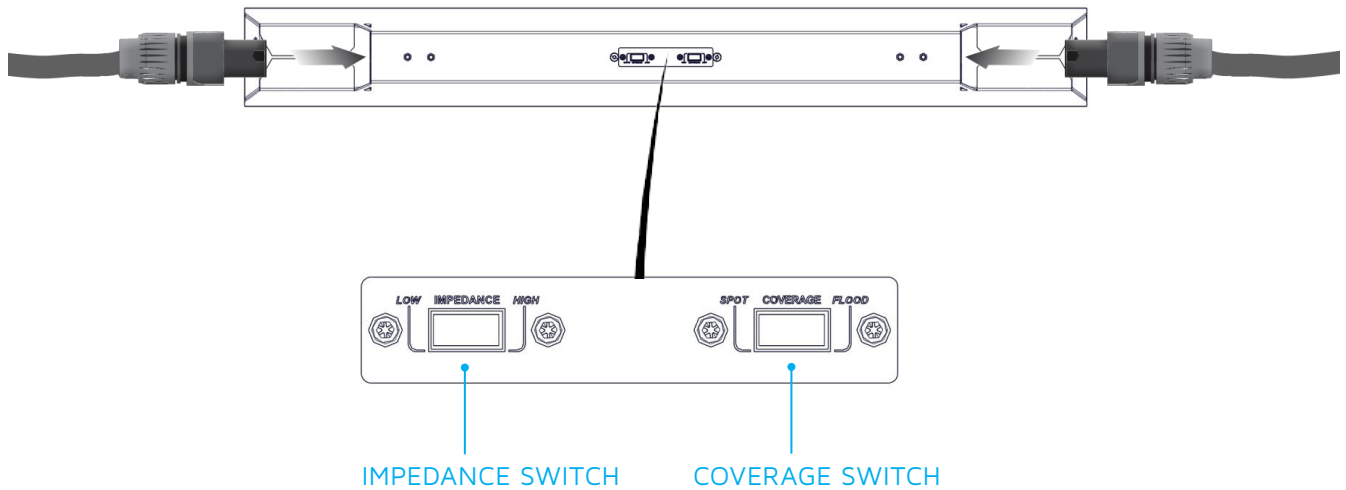

### 7.1 IMPEDANCE SWITCH

KK52 and KK102 features a switch which allows users to select the impedance of the speaker (KK52: 16/64 Ω, KK102: 8/32 Ω).

The value to be selected depends mainly on the amplifier you use to drive the unit. Impedance must be set to high (64 Ω for KK52 and 32 Ω for KK102) when speakers are driven by KMT active modules or by the KA84 amplifier. Low impedance may be used when speakers are driven by a KA24 amplifier. Please refer to your amplifier’s specifications to select the correct speaker impedance for your configuration.

	KA24 amp	KA84 amp	KMT sub
KK52 @ 16 Ω	YES	NO	NO
KK52 @ 64 Ω	NO	YES	YES
KK102 @ 8 Ω	YES	NO	NO
KK102 @ 32 Ω	NO	YES	YES



## 7.2 COVERAGE SWITCH

KK52 and KK102 features a switch which allows users to select the vertical coverage of the speaker. Flood coverage sets a wide vertical diffusion. Flood coverage is suggested for single speakers in diffused short throw applications to obtain maximum diffusion with a minimum footprint.

Spot coverage sets a narrower vertical diffusion angle and is recommended for long throw or monitoring application.

When more units are combined in a line array configuration, make sure to set the coverage to Spot.

SPOT Coverage



FLOOD Coverage

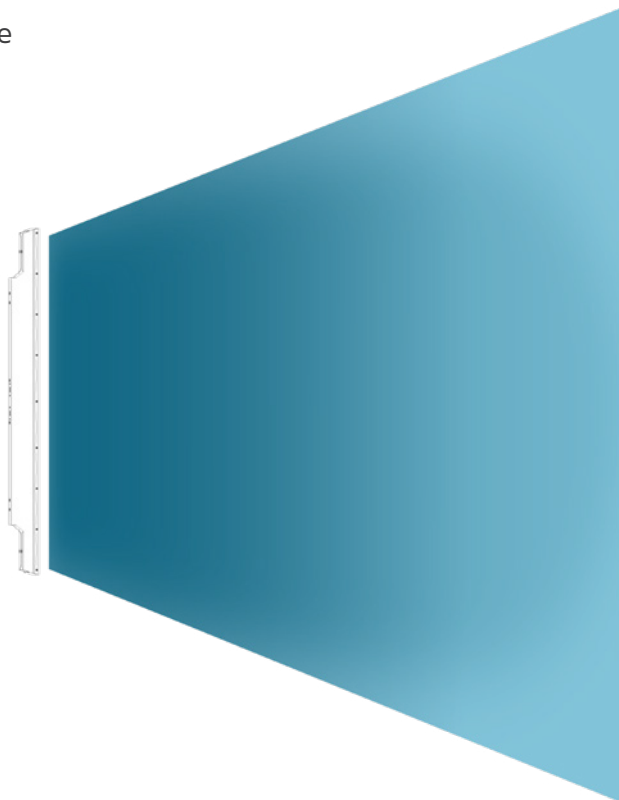

## 8. ACCESSORIES AND CONFIGURATIONS

K-array offers a variety of dedicated accessories to mount and interconnect the speakers for a wide range of applications.

In this section we introduce you to the main accessories available for this product.

### 8.1 SUSPENDING FROM THE FLY-BAR

KK52 and KK102 units can be suspended using the K-FLY2 fly bar accessory and the K-JOINT2 hardware accessory used to connect together two units or to connect a unit to the fly bar. Mixed configuration with both KK52s and KK102 in the same cluster are also possible.

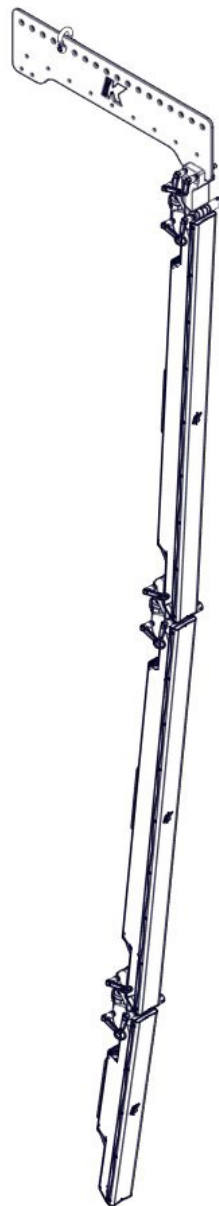

Consult the dedicated K-FLY2 manual for safety information and operation details.



### 8.2 HANGING ON THE WALL

The K-WALL2 and K-WALL2L accessories are used to mount a speaker on a wall.

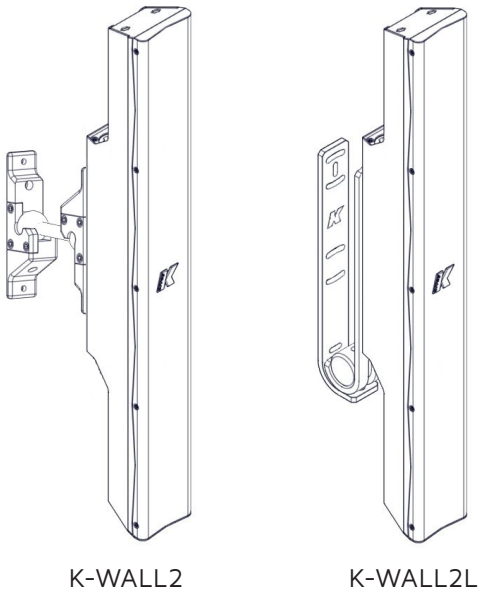

K-WALL2

K-WALL2L



In case of outdoor installation, we recommend to not remove the protection plate that covers the switches. Use the screws included in the K-WALL2 and K-WALL2L to fix the bracket to the speaker keeping the switches protected by the plate.

### 8.3 STANDING ON THE BASE

The K-BASE2 accessory assists in standing up to 2 meters of KK52/KK102. For proper installation and operation, connect the units to the base with K-FOOT2 and K-JOINT2 accessories. Where possible, screw the feet of the K-BASE2 to the ground.

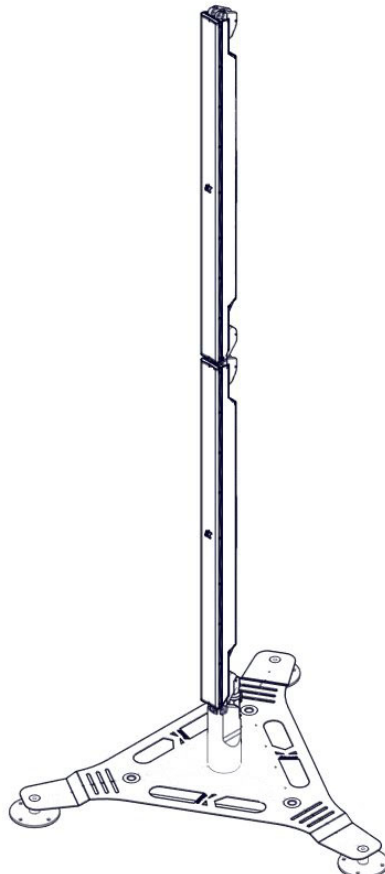

## 8.4 HORIZONTAL CLUSTER

The KK-CLUSTER2 accessory is used to mount on a horizontal cluster of three KK52/KK102 speakers on the wall.

KK-CLUSTER2 comes in a set of three different models: one with no angle between the three speakers, one with a 30° angle between the speakers, one with a 60° angle between the speakers.

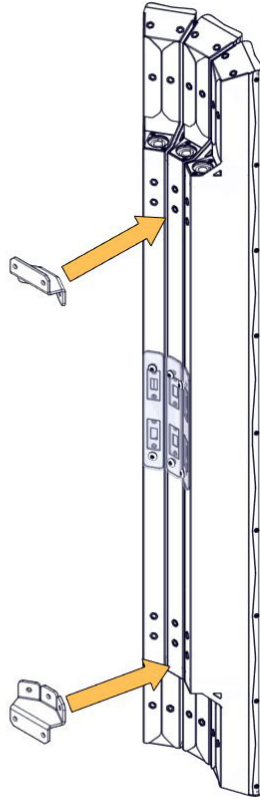

## 8.5 GROUND LAYING

The KK-STAGE accessory is used to ground laying KK52/KK102 speakers.

KK-STAGE allows users to safely lay the speakers on the ground with three different angles: 0°, 30° and 45°. Ideal applications are monitoring and front-fill.

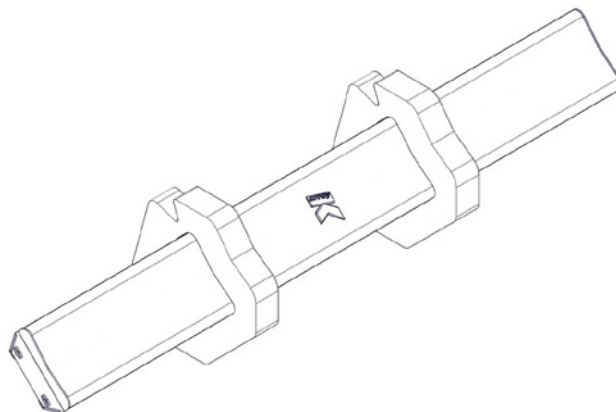

### 8.6 STANDING ON A KMT SUBWOOFER

Up to two meters of KK52/KK102 can be mounted on a KMT subwoofer by using the K-FOOT2 and K-JOINT2 accessories.

Acoustically speaking, two KK102s perfectly match with a KMT18 subwoofer. An excellent example of the use of this combination is the K-array portable system KR202.

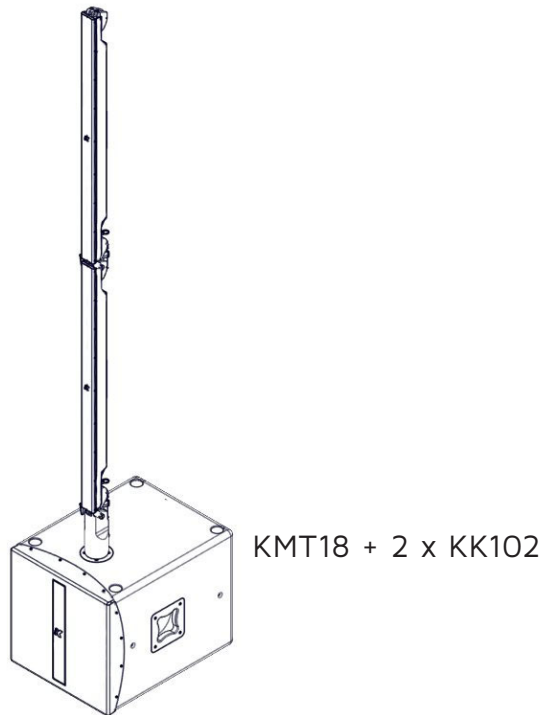

### 8.7 OUTDOOR INSTALLATION

In case of outdoor installation, use the K-IP65KITA weatherproof cap (not included) to close not connected NL4 sockets. Use the K-IP65KITB weatherproof rubber cable cover (not included) to further protect wired NL4 connectors. We also recommend to not remove the protection plate that covers the switches.

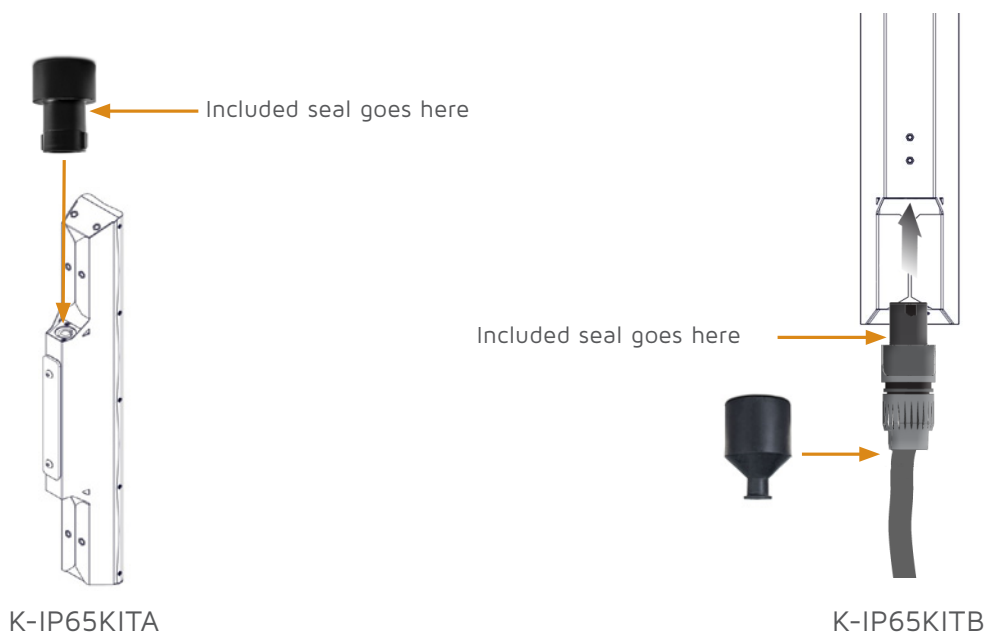

## 9. SERVICE

To obtain service:

- 1) Contact the official K-array distributor in your country. Your local distributor will direct you to the appropriate service center.
- 2) If you are calling for service, please have the serial number(s) of the unit(s) available for reference. Ask for Customer Service and be prepared to describe the problem clearly and completely.
- 3) If the problem cannot be resolved over the phone, you may be required to send the unit in for service. In this instance, you will be provided with an RA (Return Authorization) number which should be included on all shipping documents and correspondence regarding the repair. Shipping charges are the responsibility of the purchaser.

Any attempt to modify or replace components of the device will invalidate your warranty. Service must be performed by an authorized K-array service center.



### Cleaning:

Use only a soft, dry cloth to clean the product. Do not use any solvents, chemicals, or cleaning solutions containing alcohol, ammonia, or abrasives. Do not use any sprays near the product or allow liquids to spill into any openings.

## 10. TECHNICAL SPECIFICATIONS

### **KK52**

	<b>ACOUSTICS</b>
Rated Power	200 W
Frequency range	150 Hz – 18 kHz (- 10dB) <sup>(1)</sup>
Impedance	16 Ω / 64 Ω (selectable)
Maximum SPL	120 dB (peak) <sup>(2)</sup>
	<b>COVERAGE</b>
Horizontal	120°
Vertical	10° / 60° (selectable)
	<b>CROSSOVER</b>
Type	External crossover required
Frequency	High pass @ 150 Hz, 24 dB/oct suggested minimum
	<b>TRANSDUCERS</b>
Full range	8 x 2" Neodymium magnet cone drivers with 0.75" voice coil
	<b>SELECTION SWITCHES</b>
Impedance	16 Ω / 64 Ω
Coverage	Spot / Flood
	<b>POWER AUDIO INPUT/OUTPUT</b>
Connector	2 x 4-pin Speakon
Wiring	1+ 1- (signal IN & LINK); 2+ 2- (through)
	<b>RECOMMENDED AMPLIFIERS</b>
Type	KA24, KA84, KMT
	<b>CERTIFICATION</b>
IP	54
	<b>PHYSICAL</b>
Dimensions	59 x 497 x 81 mm (2.3 x 19.6 x 3.2 in)
Weight	2.3 kg (5.07 lbs)

### **KK102**

	<b>ACOUSTICS</b>
Rated Power	400 W
Frequency range	150 Hz – 18 kHz (- 10dB) <sup>(1)</sup>
Impedance	8 Ω / 32 Ω (selectable)
Maximum SPL	126 dB (peak) <sup>(2)</sup>
	<b>COVERAGE</b>
Horizontal	120°
Vertical	7° / 35° (selectable)
	<b>CROSSOVER</b>
Type	External crossover required
Frequency	High pass @ 150 Hz, 24 dB/oct suggested minimum
	<b>TRANSDUCERS</b>
Full range	16 x 2" Neodymium magnet cone drivers with 0.75" voice coil
	<b>SELECTION SWITCHES</b>
Impedance	8 Ω / 32 Ω
Coverage	Spot / Flood
	<b>POWER AUDIO INPUT/OUTPUT</b>
Connector	2 x 4-pin Speakon
Wiring	1+ 1- (signal IN & LINK); 2+ 2- (through)
	<b>RECOMMENDED AMPLIFIERS</b>
Type	KA24, KA84, KMT
	<b>CERTIFICATION</b>
IP	54
	<b>PHYSICAL</b>
Dimensions	59 x 1000 x 81 cm (2.3 x 39.4 x 3.2 in)
Weight	4.8 kg (10.6 lbs)

Notes for data

1. With dedicated preset;
2. Maximum SPL is calculated using crest factor 4 (12dB) from sensitivity scaled @1m and power handling specifications, exclusive of power compression.

New materials and design are introduced into existing products without previous notice. Present systems may differ in some respects from those presented in this catalogue.

## 11. EN54-24 DATA

KK52 I and KK102 I are EN54-24 compliant. Consider the specifications below when either model is used in a voice alarm system.

### **KK52 I**

Power handling	15 W
SPL 1W/1m	95 dB
Maximum SPL	106 dB
Connector IN	1+ 1-
Vmax In (Pink Noise)	11.60 V @ 16 Ohm
	23.20 V @ 64 Ohm
Frequency Range	150 Hz - 20 kHz
Coverage Horizontal	180° @ 500 Hz
	180° @ 1000 Hz
	180° @ 2000 Hz
	105° @ 4000 Hz
Coverage Vertical	55° @ 500 Hz
	30° @ 1000 Hz
	20° @ 2000 Hz
	15° @ 4000 Hz

### **KK102 I**

Power handling	15 W
SPL 1W/1m	98 dB
Maximum SPL	109 dB
Connector IN	1+ 1-
Vmax In (Pink Noise)	8.20 V @ 8 Ohm
	16.40 V @ 32 Ohm
Frequency Range	150 Hz - 20 kHz
Coverage Horizontal	180° @ 500 Hz
	180° @ 1000 Hz
	180° @ 2000 Hz
	110° @ 4000 Hz
Coverage Vertical	22° @ 500 Hz
	15° @ 1000 Hz
	10° @ 2000 Hz
	7° @ 4000 Hz

K-array 0068-CPR-xxx /2017
EN 54-24 : 2008 Loudspeaker for voice alarm systems for fire detection and fire alarms systems for buildings  KK52 I  TYPE B

K-array 0068-CPR-xxx /2017
EN 54-24 : 2008 Loudspeaker for voice alarm systems for fire detection and fire alarms systems for buildings  KK102 I  TYPE B