



# COM104

## Public Address Amplifier 40W 100V

### Highlights:

---

- unbalanced stereo line input
- 1 x Microphone input
- Priority audio inputs with phantom power
- 1 x Priority mute contact
- Terminal block output connections (4Ω, 70V, 100V)
- Compact design
- Low impedance & constant voltage output
- Table top or half rackspace installation



The COM104 is a compact but versatile public address mixing amplifier which offers solutions for small to medium size audio systems in commercial installations. Typical applications are background music systems in retail stores, bars, restaurants and office buildings.

The compact and simple design allows installation in any location and operation through any possible user.

The amplifier is designed using Class-D amplifier technology and delivers an output power of 40 Watt to constant voltage (100V and 70V) or low impedance (4 Ohm) audio systems. A switch mode power supply allows compatibility with a wide variation of mains voltages for global compatibility.

A stereo line input allows connection for a wide variation of audio sources such as media players, radio tuners, internet audio players, ... and many more. A balanced mic/line input allows connection for an announcement microphone with compatibility for condenser microphones using the integrated phantom power supply (15V). A priority switch overrides the background music when enabled, and compatibility with voice file players is guaranteed by the wide gain adjustment possibility (0 dB - +50 dB).

The COM104 is a table-top standing device, while rack mounting in 10.5" or 19" equipment racks is possible using an optionally available mounting set (MBS310).



### Applications:

---

- Bars, restaurants
- Retail
- Public facilities
- Corporate spaces

## System specifications:

Inputs	Balanced Microphone	Sensitivity (1W/1m)	-0 dB ~ +50 dB
		Connector	3-pin Euro Terminal Block (Pitch - 3.81 mm)
		Type	1 x Balanced Microphone
	Unbalanced Stereo	Type	1 x Stereo Unbalanced Line
		Connector	RCA / 3.5 mm Jack
		Sensitivity (1W/1m)	-4 dB ~ +20 dB
Frequency	Response ( $\pm 3$ dB)		20 Hz - 20 kHz
Signal / Noise			> 90 dB
THD+N (@ 1 kHz)			< 0.5% (1/2 Rated Power)
Crosstalk (@ 1 kHz)			> 70 dB
Technology			Class-D
Power	Supply		Switching mode
		Operating	100 ~ 240 V AC / 50 ~ 60 Hz
Inputs	Balanced Microphone	Phantom Power	15 V DC
			Priority mute contact
Outputs	Connector		4-pin Euro Terminal Block (Pitch - 5.08 mm)
	Voltage / Impedance		100/ 70 V / 4 $\Omega$
Protection	Amplifier		DC Short circuit
			Over heating
			Over load
			Signal limiting
Cooling			Convection cooled
Operating temperature			0° ~ 40° @ 95% Humidity
RMS Power	@ 4 $\Omega$		1 x 40 W

## Product Features:

Dimensions		217.5 x 43.7 x 300 mm (W x H x D)
Weight		3 kg
Mounting		1/2 19" / 1 HE or tabletop
Construction		Steel
Colours		Black
Accessories	Optional	19" Rackmount adapter

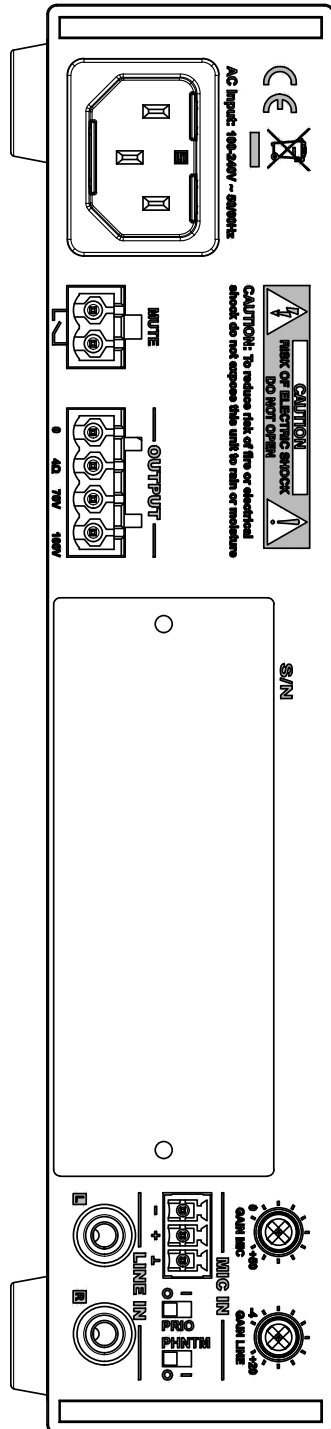
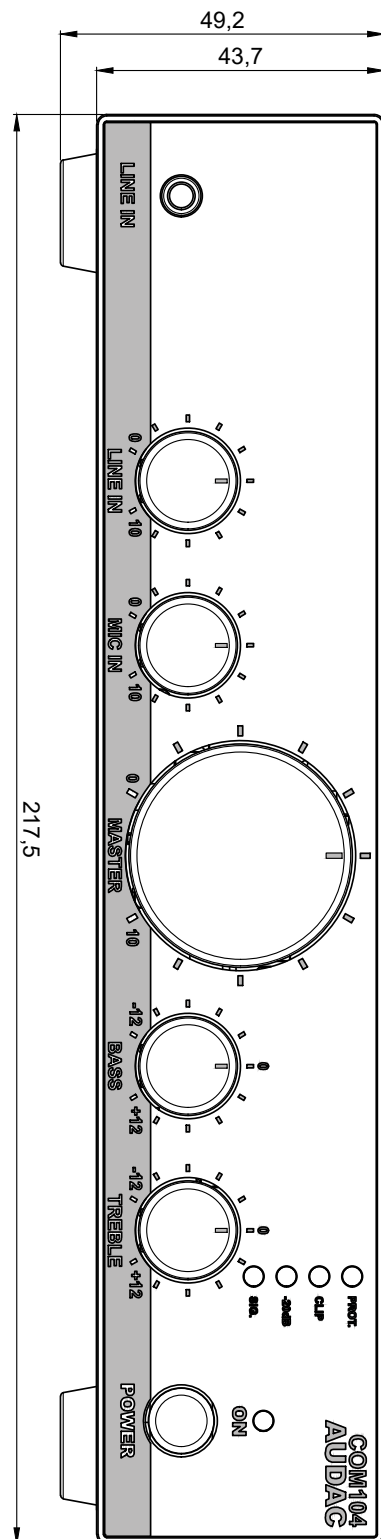

<b>COM104</b>		<b>Product description:</b> PUBLIC ADDRESS AMPLIFIER 40W 100V	
<b>Weight:</b>	2,12 kg	<b>Outer dimensions:</b> (w x h x d)	217,5 X 49,2 X 300,3
<b>Unit height:</b>	1 HE		